

RT55/B (Hinge Door version)

55 LBS THRUST

12 VOLT

52" SHAFT

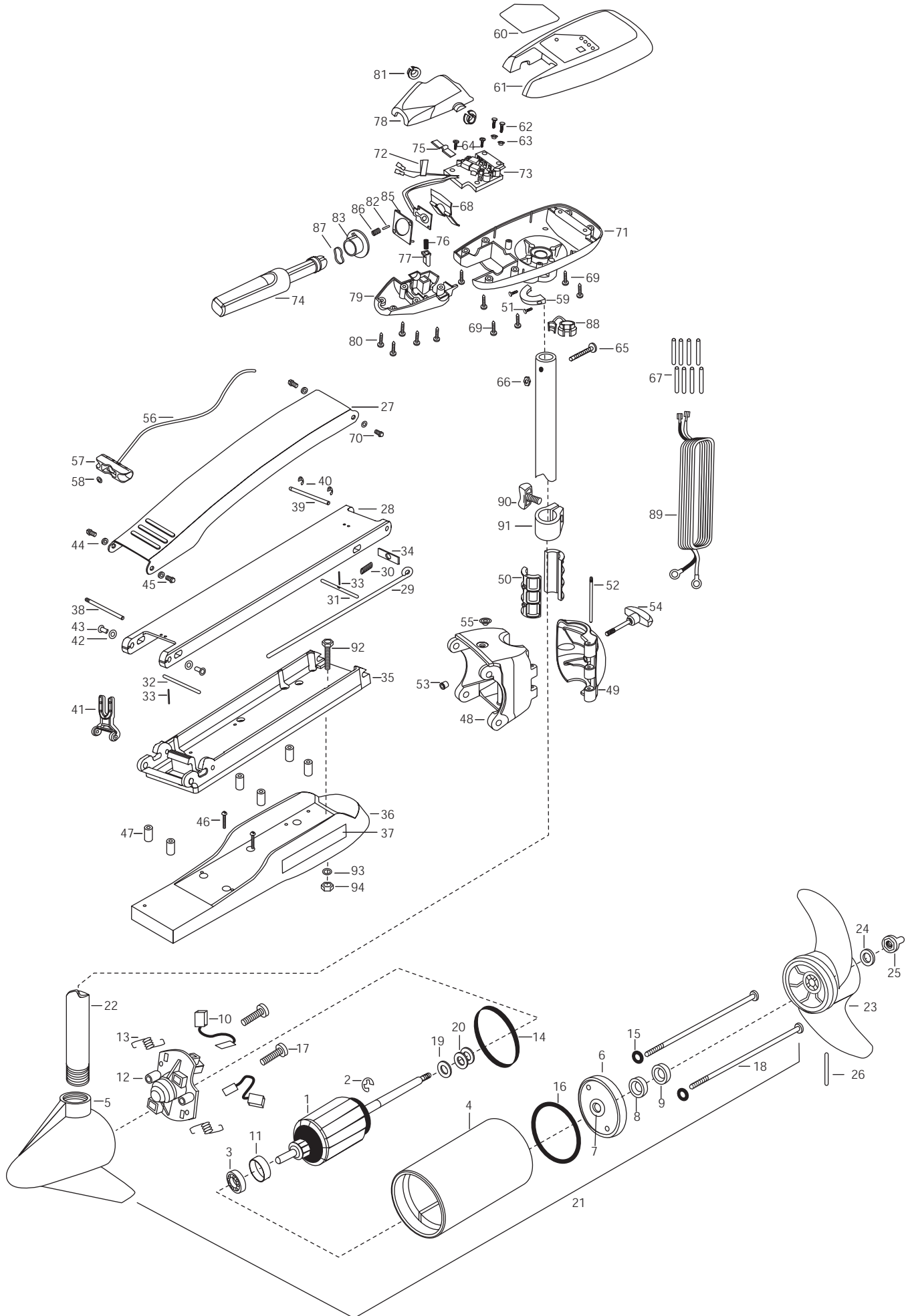

1	92-100-013	ARMATURE ASSEMBLY12V 3.625	31	2233601	LOCKBAR (SS) (NEW 500)	63	2301710	WASHER-INSUL. (TRANSF.BAR) [2. EA]
2	788-015	RETAINING RING	32	2233603	LOCK BAR, REAR S/S	64	2372100	SCREW-8-18 X 5/8 THD (SS) [2. EA]
3	140-010	BEARING -BALL	33	2152610	SPRING-PIN (LOCKBAR) [2. EA]	65	2263406	SCREW-10-24 X 2" SS PPH
4	2-200-301	CENTER HOUSING ASSEMBLY 3.625 WHT	34	2262703	SPRING STOP	66	2333101	NUT-HEX 10-24 UNC-2B NYLOC
5	421-336	HOUSING- BRUSH END 3.625 SW WHI	35	2993983	BOWPLATE/INSRT ASSEMBLY,STD,SW	67	2305400	SHRINK TUBE-3/8 OD X 1-1 [8. EA]
6	2-400-337	PLAIN END HOUSING ASSEMBLY 3.625	36	2263914	MOTOR REST STD MAXXUM WHT	68	2302743	SPRING-DETENT -HANDLE-TILT
7	144-049	BEARING - FLANGE [SERVICE ONLY]	37	2065676	DECAL-MOTOR REST RT/W [2. EA]	69	2303412	SCREW-6-20 X 5/8 SELF TAP [6. EA]
8	880-003	**SEAL	38	2260505	PIN-HINGE (HEADLESS) S/S	70	2263500	BOLT, SHOULDER [2. EA]
9	880-006	**SEAL WITH SHIELD	39	2260512	HINGE PIN (MAX,A/T) S/S	71	2062596	CONTROL BOX, SW, .725 BORE WHT
10	188-036	BRUSH ASSEMBLY [2. EA]	40	2263011	E-RING 3/8 DIA. SHAFT [2. EA]	72	2305810	TAG-AIR SWITCH LEADS
11	725-050	PAPER TUBE- BRUSH RETENTION	41	2293811	YOKE,MAX MNT-POLYPROPYLENE	73	2334007	CONTROL BOARD ASSEMBLY
12	738-036	BRUSH PLATE W/HOLDER 3.625	42	2261708	WASHER-3/8X1/2X.016 (SS) [2. EA]	74	2990915	HANDLE ASSEMBLY W/O U-JOINT
13	975-040	SPRING - TORSION [2.EA]	43	2236000	BEARING NYLINER [2. EA]	75	2302742	SPRING-DETENT(OFF) SS
14	337-036	**GASKET	44	2293501	BUSHING, STAINLESS STEEL [4. EA]	76	2302745	SPRING-RELEASE BUTTON SS
15	701-008	**O-RING [2. EA]	45	2263500	BOLT, SHOULDER [2. EA]	77	2303720	RELEASE BUTTON-HANDLE
16	701-081	**O-RING	46	2263434	SCREW, 8-18 X 1" PPH SS [2. EA]	78	2060411	HANDLE (TOP HALF)
17	830-007	SCREW # 8-32 [2.EA]	47	2261505	SPACER, MOTOR REST [6. EA]	79	2060415	HANDLE (LOWER HALF)
18	830-042	THRU BOLT 10-32 X 8.83 [2. EA]	48	2991863	HINGE BASE/INSERT ASSEMBLY,SW,	80	2303412	SCREW-6-20 X 5/8 SELF TAP [5. EA]
19	990-067	WASHER - STEEL THRUST	49	2261859	HINGE DOOR STD WHT TEX	81	2060005	BEARING-HANDLE PIVOT [2. EA]
20	990-070	WASHER - NYLATRON [2. EA]	50	2151532	HINGE-SLEEVE HALF-AT [2. EA]	82	2302600	PIN-ACTUATOR
21	2099095	MOTOR- ASSEMBLY 12V 3.62 SW VARS	51	2223430	SCREW- #8X3/4 PPH TYPE 25 SS [2.EA]	83	2302850	ACTUATOR-CAM
22	2032034	TUBE-CARBON COMPOSITE 52" WHT	52	2262642	PIN-HINGE DOOR, RT HNG,	85	2302851	ACTUATOR-FWD/REV
■	1378122	PROPELLER KIT	53	2264706	INSERT-HINGE BASE (STD MT)	86	2302740	SPRING- (ACTUATOR)
23	2091150	PROPELLER (W.WEDGE)	54	2260186	KNOB-HINGE COVER SW S/S	87	2302741	SPRING-CAM (ZNC PLTD STEEL)
24	2151726	WASHER- 5/16 STD	55	2232315	EYELET-ROPE STAINLESS STEEL	88	2332900	STRAIN RELIEF-C.CORD/SP.C
25	2198400	ANODE-ZINC 3.25/3.625 LWR U	56	2251601	ROPE (40"),	89	2330600	LEADWIRE (10 GA-4) (RINGS)
26	2092600	PIN-DRIVE	57	2150400	PULL-GRIP	90	2011366	SCREW-COLLAR/NEW KNOB (SS)
■	2991886	MOUNT,BOW ASSEMBLY,SW STD HNGD	58	2151700	WASHER-EYE SHAFT(.562 OD)	91	2031520	COLLAR-DEPTH (W/O INSERT)
27	2264244	ARM-UPPER STD SW TXT WHT	59	2061517	COLLAR-CTRL BOX SW WHT	■	2994830	BAG ASSEMBLY
28	2994310	ARM-LOWER ASY STD WHT SW	60	2195626	DECAL-COVER, RT55/B HC	*92	2263431	SCREW 1/4-20 X 3.5 PPH [6. EA]
29	2153603	EYE SHAFT-2 LOCKBAR STD SS	61	2300219	COVER- CONTROL BOX RIPTIDE WHT	*93	2261713	WASHER-1/4 FLAT S/S [6. EA]
30	2152701	SPRING-(LOCKBAR) SS	62	2301310	SCREW-8-18 X 1/2 SS [2. EA]	*94	2263103	NUT-1/4-20 NYLOCK-JAM S/S [6. EA]

****Seal & Oring Kit P/N 2888460**

* This item is part of an assembly. This item cannot be sold separately due to machining and /or assembly that is required.

P/N 2194922 REV. B 1-02

BLACK

RT55/B/HC Wiring Diagram

