

RT55/AP
55 LBS THRUST
12 VOLT
48" OR 54" SHAFT

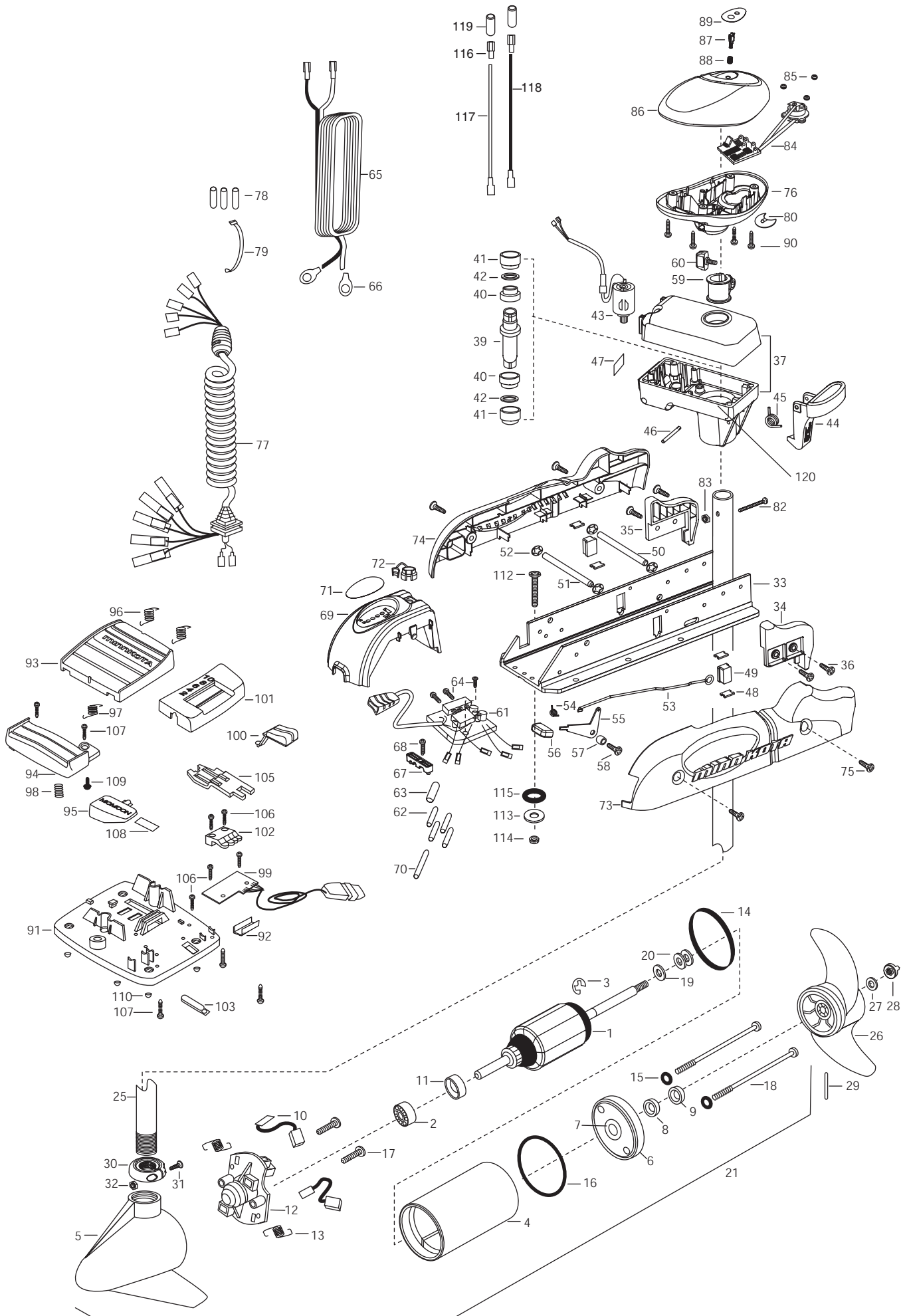

| | | | | | | | | |
|-----|------------|--|-----|---------|-----------------------------------|------|---------|--------------------------------------|
| 1 | 92-100-013 | ARMATURE ASSEMBLY | *42 | 2304603 | O-RING [2.EA] | 82 | 2332102 | SCREW-10-24 X 1-3/4 |
| 2 | 140-010 | BALL BEARING | 43 | 2307045 | MOTOR- DRIVE HOUSING HIGH SPD | 83 | 2333101 | NUT-HEX 10-24 NYLOC |
| 3 | 788-015 | RETAINING RING | 44 | 2307215 | LATCH HANDLE PD/AP | 84 | 2994023 | CNTRL BRD/CMPSS ASSMBLY |
| 4 | 2-200-301 | HOUSING ASSEMBLY CENTER 3.62 W/MA | 45 | 2302750 | SPRING- LATCH TORSION PD/AP | 85 | 2302960 | GROMMET-COMPASS [3.EA] |
| 5 | 421-336 | HOUSING BRUSH END 3.62 WHITE | 46 | 2302626 | PIN- ROLL 3/16X2 SS | 86 | 2300243 | CONTROL BOX COVER- RIPTIDE WHITE |
| 6 | 2-400-337 | PLAIN END HOUSING ASSEMBLY 3.625 | 47 | 2305514 | DECAL-STOW/DEPLOY PD/AP'2001 | 87 | 2304082 | ACTUATOR- SWITCH ON/OFF A/P |
| 7 | 144-049 | BEARING - FLANGE (SERVICE ONLY) | 48 | 2335110 | PAD-PIVOT SUPT SS [4.EA] | 88 | 2302752 | SPRING- ACTUATOR PD/AP SS |
| 8 | 880-003 | **SEAL | 49 | 2305101 | PIVOT PAD [2.EA] | 89 | 2305669 | DECAL- COVER ON/OFF 55PD/AP |
| 9 | 880-006 | **SEAL WITH SHIELD | 50 | 2330510 | PIN-LATCH PD BASE SS | 90 | 2372100 | SCREW-8-18 X 5/8 SS [4.EA] |
| 10 | 188-036 | BRUSH ASSEMBLY [2.EA] | 51 | 2330520 | PIN-PIVOT PD BASE SS | ■ | 2774700 | FOOT PEDAL ASSEMBLY |
| 11 | 725-050 | BRUSH RETENTION- PAPER TUBE | 52 | 2333100 | NUT-SPEED SS [4.EA] | 91 | 2304511 | FOOT PEDAL BASE |
| 12 | 738-036 | BRUSH PLATE W/HOLDER | 53 | 2303612 | ROD-RELEASE RT/AP SS | 92 | 2308500 | WEAR PLATE FOOT PDL |
| 13 | 975-040 | SPRING - TORSION [2.EA] | 54 | 2302700 | SPRING-RELEASE LEVER | 93 | 2304516 | FOOT PEDAL-UPPER |
| 14 | 337-036 | **GASKET | 55 | 2333705 | LEVER-RELEASE SS | 94 | 2304520 | FOOT PEDAL-LOWER |
| 15 | 701-008 | **O-RING, THRU-BOLT [2.EA] | 56 | 2300101 | RELEASE-KNOB | 95 | 2307210 | LEVER MOM/CON- |
| 16 | 701-081 | **O-RING | 57 | 2301700 | SPACER-RELEASE LEVER | 96 | 2302730 | SPRING-LONG-UPPER PEDAL [2.EA] |
| 17 | 830-007 | SCREW-8-32 [2.EA] | 58 | 2332104 | SCREW-1/4-20 X 5/8 SS | 97 | 2302731 | SPRING-SHORT-UPPER PEDAL |
| 18 | 830-042 | THRU-BOLT 10-32X8.83 [2.EA] | 59 | 2031522 | COLLAR- DRIVE (W/INSERT) | 98 | 2302732 | SPRING-LOWER PEDAL |
| 19 | 990-067 | WASHER- STEEL THRUST | 60 | 2011366 | SCREW-COLLAR/NEW KNOB SS | 99 | 2304012 | CONTROL BOARD ASSEMBLY-FT PDL |
| 20 | 990-070 | WASHER - NYLATRON [2.EA] | 61 | 2304041 | CONTROL BOARD ASSEMBLY- 12V PD/AP | 100 | 2300120 | KNOB-SPEED SELECTOR |
| 21 | 2099095 | MOTOR ASSMBLY 12V 3.62 VARS SW WHT | 62 | 2305400 | SHRINK TUBE-3/8 [4EA.] | 101 | 2300121 | HOUSING SPEED SELECTOR |
| 25 | 2032021 | TUBE-COMPOSITE 48" AP/WHITE | 63 | 2375400 | SHRINK TUBE- 1/4ODX1-3/4 | 102 | 2302840 | ACTUATOR-BOARD |
| | 2032022 | TUBE-COMPOSITE 54" AP/WHITE | 64 | 2332100 | SCREW-8-32 X 3/8 [3.EA] | 103 | 2302841 | ACTUATOR-MOM/CON |
| ■ | 1378122 | PROPELLER KIT | 65 | 2090601 | LEADWIRE IOGA 44" | 105 | 2302842 | ACTUATOR-STEERING |
| 26 | 2091150 | PROPELLER W/WEDGE | 66 | 2020700 | TERMINAL RING [2.EA] | 106 | 2302100 | SCREW-6-20 X 1/2 [5.EA] |
| 27 | 2151726 | WASHER-5/16 SS | 67 | 2222906 | STRAIN RELIEF- BRACKET PD/AP | 107 | 2372100 | SCREW-8-18 X 5/8 [5.EA] |
| 28 | 2198400 | ANODE- ZINC 3.25/3.625 LWR U | 68 | 2332104 | SCREW-1/4-20 X 5/8 SS | 108 | 2266610 | DECAL-ON/OFF SWITCH |
| 29 | 2092600 | PIN-DRIVE | 69 | 2306556 | HOUSING- CENTER PD/AP WHITE | 109 | 2335130 | BUMPER ACTUATOR |
| 30 | 2301555 | COLLAR- LATCH PD/AP | 70 | 2355410 | SHRINK TUBE-3/8X2 | 110 | 2994807 | BAG ASSEMBLY- 4 RUBBER BUMPERS |
| 31 | 2303434 | SCREW- 8-32X5/8 MACH PHCR | 71 | 2306612 | DECAL- BATT GAUGE H RT AP | ■ | 2994812 | BAG ASSEMBLY- (BOLT,NUT,WASHERS) |
| 32 | 2303112 | NUT 8-32 NYLOC SS | 72 | 2302935 | STRAIN RELIEF-DR. HOUSING | *112 | 2333500 | BOLT-MOUNTING-SS [6.EA] |
| 33 | 2301933 | EXTRUSION- BASE ANODIZED | 73 | 2303944 | SIDEPLATE (RIGHT) WHITE | *113 | 2151726 | WASHER-5/16 SS [6.EA] |
| 34 | 2303932 | MOTOR REST- RIGHT LARGE | 74 | 2303949 | SIDEPLATE(LEFT) WHITE | *114 | 2383106 | NUT-5/16-18 MOUNTING SS[6.EA] |
| 35 | 2303937 | MOTOR REST- LEFT LARGE | 75 | 2332104 | SCREW-1/4-20 X 5/8 SS | *115 | 2301720 | WASHER-MOUNTING RUBBER [6.EA] |
| 36 | 2332104 | SCREW 1/4-20X5/8 SELF TAP SS [4.EA] | 76 | 2302516 | CONTROL BOX PD/AP WHITE | 116 | 2030710 | BUTT CONNECTOR |
| 37 | 2301847 | DRIVE HOUSING AP SW WHITE | 77 | 2991260 | COIL CORD WSTRAIN RELIEF 48" | 117 | 2030317 | WIRE EXTENSION 18" RED |
| ■ | 2882011 | BUSHING/ OUTSHAFT KIT (INCLUDES 39-42) | | 2991261 | COIL CORD WSTRAIN RELIEF 54" | 118 | 2030316 | WIRE EXTENSION 18" BLACK |
| *39 | 2302010 | DRIVE HOUSING OUTPUT SHAFT | 78 | 2065400 | WIRE INSULATOR-LGE 1-3/4 [3.EA] | 119 | 2375400 | SHRINK TUBE 1/4" OD X 1 3/4" [2 EA.] |
| *40 | 2307304 | BUSHING- INNER [2.EA] | 79 | 9950433 | TIE WRAP-4" BLACK | 120 | 2304604 | O-RING CASE SEAL |
| *41 | 2307305 | BUSHING- OUTER [2.EA] | 80 | 2224701 | INSERT- PLUG WHITE | | | |

**Seal & Oring Kit P/N 2888460

* This item is part of an assembly. This item cannot be sold separately due to machining and /or assembly that is required.

P/N 2304999 REVA 7-02

