

MAXXUM 74/H - 52"
74 LBS THRUST
24 VOLT
52" SHAFT

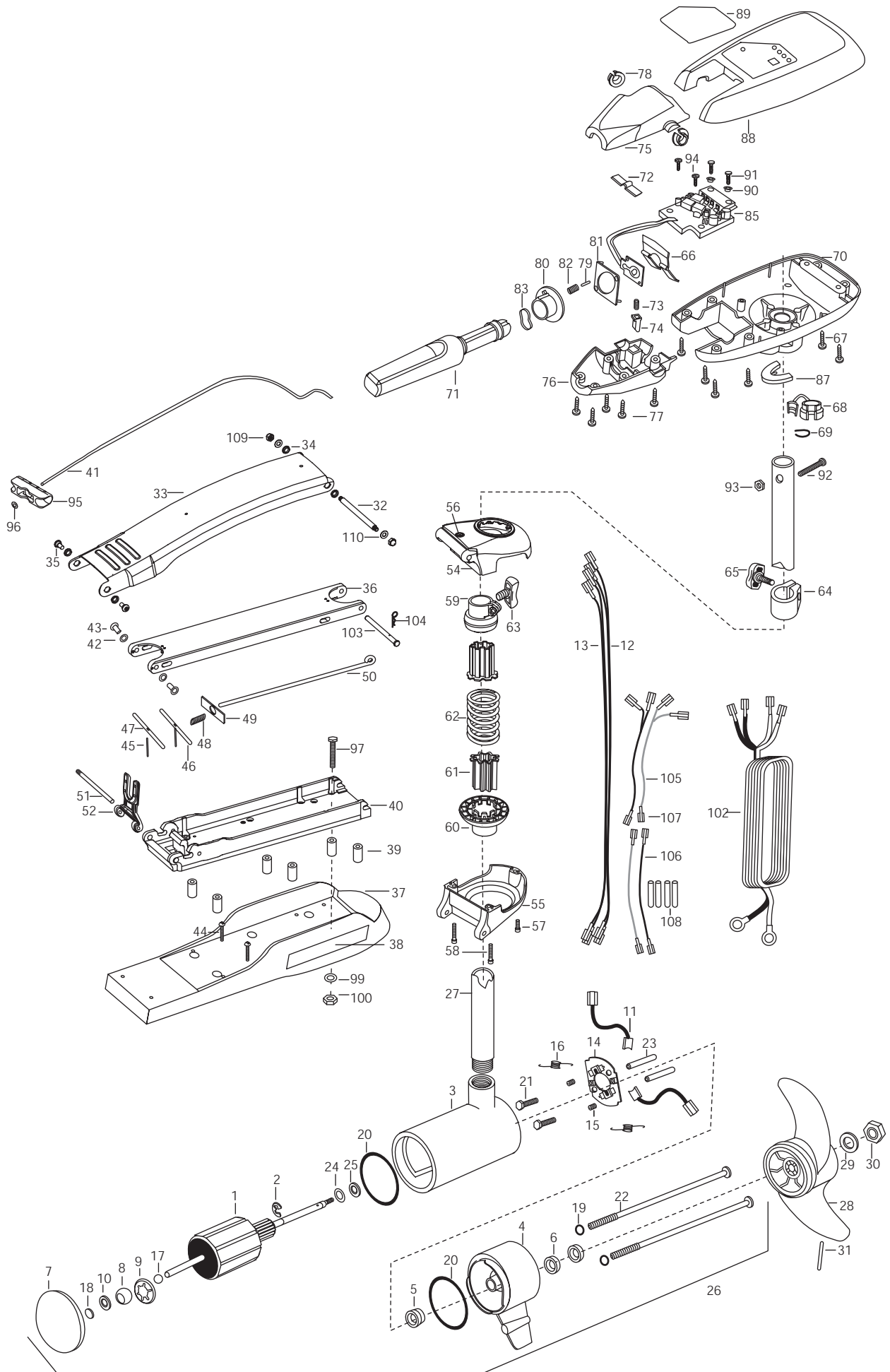

1	2-100-103	ARMATURE ASSEMBLY 24V 4" FW SW 74#	36	2994307	ARM-LOWER ASSY,STD,FW,EX	73	2302745	SPRING-RELEASE BUTTON SS
2	788-040	RETAINING RING	37	2263912	MOTOR REST STD MAX	74	2303720	RELEASE BUTTON-HANDLE
3	431-160	HOUSING ASSEMBLY CENTER 4.0 TXT	38	2265514	DECAL-MAXXUM,MOTOR REST [2.EA]	75	2060409	HANDLE (TOP HALF)MAXIMIZE
4	2-300-160	BRUSH END HOUSING ASSEMBLY FW TXT	39	2261505	SPACER, MOTOR REST [6.EA]	76	2060415	HANDLE (LOWER HALF)
5	144-017	BEARING- FLANGE (SERVICE ONLY)	40	2773987	BOWPLATE,STD FW-MACH/INSERT	77	2303412	SCREW-6-20 X 5/8 SELF TAP [5.EA]
6	880-025	**SEAL [2.EA]	41	2251601	ROPE (40"), MAXXUM MOUNT	78	2060005	BEARING-HANDLE PIVOT [2.EA]
7	2-400-160	PLAIN END HOUSING ASSEMBLY	42	2261707	WASHER-3/8"X1/2"X.016 SS [2.EA]	79	2302600	PIN-ACTUATOR
8	144-021	BEARING SPHERICAL	43	2236000	BEARING NYLINER- [2.EA]	80	2302850	ACTUATOR-CAM
9	784-025	BEARING RETAINER	44	2263434	SCREW, 8-18 K 1" PPH SS [2.EA]	81	2302851	ACTUATOR-FWD/REV
10	991-040	WASHER- FELT	45	2152610	SPRING-PIN (LOCKBAR) [2.EA]	82	2302740	SPRING- (ACTUATOR)
11	186-094	BRUSH 4." [2.EA]	46	2233600	LOCK BAR- (BOW MOUNT)	83	2302741	SPRING-CAM ZNC PLTD STEEL
12	640-015	BRUSH WIRE- BLK 10 AWG 55 XLP	47	2233602	LOCK BAR, REAR - ZINC	85	2344005	CONTROL BOARD ASSEMBLY
13	640-115	BRUSH WIRE RED 10 AWG 56 1/2	48	2152700	SPRING-(LOCKBAR) CAD.PLT	87	2061512	COLLAR-CTRL BOX (FRS-WTR)
14	738-040	BRUSH PLATE	49	2262703	SPRING STOP MAX	88	2990294	CONTROL BOX COVER/DECAL ASSEMBLY
15	830-028	SCREW- 10-32X.164 [2.EA]	50	2153602	EYE SHAFT-2LOCKBAR STD	89	2265535	DECAL COVER, MAXXUM 74/H
16	975-041	SPRING- TORSION [2.EA]	51	2260506	HINGE-PIN (HEADLESS)ZINC	90	2301710	WASHER-INSUL. (TRANSF.BAR) [2.EA]
17	116-025	BALL- STEEL	52	2293811	YOKE,MAX MNT-POLYPROPYLE	91	2372100	SCREW-8-18 X 5/8 THD* SS [2.EA]
18	303-043	THRUST DISC- METAL	■	2991866	BOWGUARD ASSEMBLY-HAND CTRL	92	2383407	SCREW-10-24 X 2" PPH ZINC
19	701-009	**O-RING —THRU BOLT [2.EA]	54	2772315	BRACKET BASE TOP/EYELET	93	2383124	NUT-10-24 NYLOC (ZINC)
20	701-043	**O-RING [2.EA]	55	2991993	BRKT BTM/BEARING FW ASSEMBLY	94	2301310	SCREW-8-18 X 1/2 SS [2.EA]
21	830-027	SCREW -SELF THREAD 10-32X2 [2.EA]	56	2772352	EYELET KIT	95	2150400	PULL-GRIP (RAW)
22	830-094	THRU BOLT 12-24X10.31 [2.EA]	57	2263402	SCREW 1/4-20 K 3/4" ZINC	96	2151700	WASHER-EYE SHAFT(.562 OD)
23	973-025	SPACER- BRUSH PLATE [2.EA]	58	2263404	SCREW-1/4-20X2 1/4 SHCP [2.EA]	■	2994830	BAG ASSEMBLY-MAXXUM
24	990-051	WASHER- STEEL	59	2261525	SPRING-SLEEVE UPPER	*97	2263431	SCREW 1/4-20 X 3.5 PPH [6.EA]
25	990-052	WASHER- NYLATRON	60	2261535	SPRING SLEEVE, LOWER	*99	2261713	WASHER-1/4 FLAT SS [6.EA]
26	2317033	MTR ASSEMBLY 24V 4" VARS TXT FW	61	2264702	INSERT-TUBE B.MNT [2.EA]	*100	2263103	NUT-1/4-20 NYLOCK-JAM SS [6.EA]
27	2032081	TUBE-CARBON COMPOSITE 52"	62	2262704	SPRING, BOWGUARD, HAND CT	102	2330600	LEADWIRE 10GA. RINGS
■	1378120	PROPELLER KIT	63	2011365	SCREW-COLLAR/NEW KNOB	103	2262607	PIN- CLEVIS
28	2331120	PROPELLER (W.WEDGE)	64	2031520	COLLAR-DEPTH (W/O INSERT)	104	2260801	SPRING CLIP
29	2091701	WASHER-PROP (LARGE)	65	2011365	SCREW-COLLAR/NEW KNOB	105	2030317	WIRE EXTENSION 18" RED [2.EA]
30	2093101	NUT-PROP,NYLOC (LARGE) MAX101	66	2302743	SPRING-DETENT(HANDLE-TILT	106	2030316	WIRE EXTENSION 18"BLK [2.EA]
31	2092600	PIN-DRIVE SS	67	2303412	SCREW-6-20~X 5/8 SELF TAP [6.EA]	107	2030710	CONNECTOR BUTT [4.EA]
32	2262605	PIN- THREADED ZN	68	2332900	STRAIN RELIEF-C.CORD/C.BX	108	2375400	SHRINK TUBE 1/4ODX1-3/4 [4.EA]
■	2771866	MOUNT, BOW ASSY, FW STD W/BG	69	2303001	RING-PIG (LOXIT HILL #2)	109	2263100	NUT-NYLOC [2.EA]
33	2264241	ARM-UPPER FW,STD	70	2062586	CONTROL BOX,FW, .875 BORE,	110	9908236	WASHER ZN [2.EA]
34	2293501	BUSHING, STAINLESS STEEL [4.EA]	71	2990914	HANDLE ASSEMBLY W/O U-JOINT			
35	2263500	BOLT, SHOULDER (MAXXUM) [2.EA]	72	2302742	SPRING-DETENT (OFF) SS			

** Seal & Oring Kit P/N 2889460

* This item is part of an assembly. This item cannot be sold separately due to machining and /or assembly that is required.

P/N 2265008 REV. K 6-01

MAXXUM 74/H Wiring Diagram

