

MAXXUM 74/H - 42"
74 LBS THRUST
24 VOLT

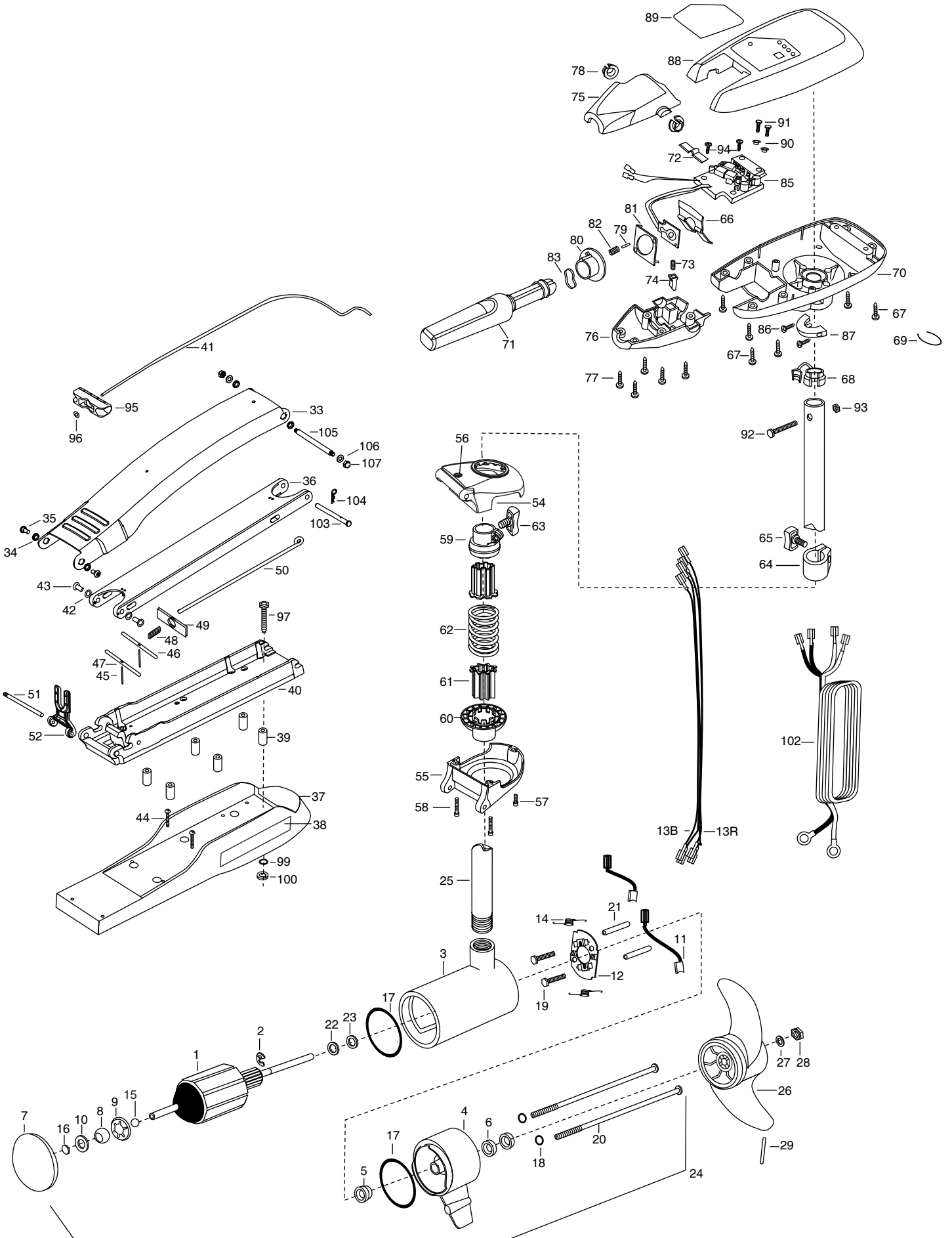

1	2-100-103	ARMATURE ASSEMBLY 24V 4"74#	36	2994307	ARM-LOWER ASSY,STD,FW,EX	71	2990914	HANDLE ASSEMBLY W/O U-JOINT
2	788-040	RETAINING RING	37	2263912	MOTOR REST STD MAX	72	2302742	SPRING-DETENT (OFF) SS
3	431-160	HOUSING ASSEMBLY CENTER 4.0 TXT	38	2265514	DECAL-MAXXUM,MOTOR REST [2.EA]	73	2302745	SPRING-RELEASE BUTTON SS
4	2-300-160	BRUSH END HOUSING ASSEMBLY	39	2261505	SPACER, MOTOR REST [6.EA]	74	2303720	RELEASE BUTTON-HANDLE
5	144-017	BEARING- FLANGE (SERVICE ONLY)	40	2773987	BOWPLATE,STD FW/INSERT	75	2060409	HANDLE- TOP HALF MAXIMIZE
6	880-025	**SEAL [2.EA]	41	2251601	ROPE- 40", MAXXUM MOUNT	76	2060415	HANDLE - LOWER HALF
7	2-400-160	PLAIN END HOUSING ASSEMBLY	42	2261708	WASHER-3/8"X1/2"X.010 SS [2.EA]	77	2303412	SCREW-6-20 X 5/8 SELF TAP [5.EA]
8	144-021	BEARING SPHERICAL	43	2236000	BEARING NYLINER- [2.EA]	78	2060005	BEARING-HANDLE PIVOT [2.EA]
9	784-025	BEARING RETAINER	44	2263434	SCREW, 8-18 K 1" PPH SS [2.EA]	79	2302600	PIN-ACTUATOR
10	991-040	WASHER- FELT	45	2152610	SPRING-PIN LOCKBAR [2.EA]	80	2302850	ACTUATOR-CAM
11	188-094	BRUSH 4" TERMINAL [2.EA]	46	2233600	LOCK BAR-BOW MOUNT	81	2302851	ACTUATOR-FWD/REV
12	738-040	BRUSH PLATE	47	2233602	LOCK BAR, REAR - ZINC	82	2302740	SPRING- ACTUATOR
13B	640-015	LEADWIRE-BLK 10 AWG [2.EA]	48	2152700	SPRING- LOCKBAR CAD.PLT	83	2302741	SPRING-CAM ZNC PLTD STEEL
13R	640-119	LEADWIRE-RED 10 AWG [2.EA]	49	2262703	SPRING STOP MAX	85	2344005	CONTROL BOARD ASSEMBLY
14	975-041	SPRING- TORSION [2.EA]	50	2153602	EYE SHAFT-2LOCKBAR STD	86	2223430	SCREW #8X3/4 PPH TYPE 25 SS [2.EA]
15	116-025	BALL- STEEL	51	2260506	HINGE-PIN HEADLESS ZINC	87	2061515	COLLAR-CTRL BOX FRS-WTR
16	303-043	THRUST DISC-METAL	52	2293811	YOKE, MAX MNT-POLYPROPYLE	88	2260290	CONTROL BOX COVER BLACK
17	701-043	**O-RING [2.EA]	■	2991866	BOWGUARD ASSEMBLY-HAND CTRL	89	2265535	DECAL COVER, MAXXUM 74/H
18	701-009	**O-RING —THRU BOLT [2.EA]	54	2772315	BRACKET BASE TOP/INSERT	90	2301710	WASHER-INSUL. TRANSF.BAR [2.EA]
19	830-027	SCREW -SELF THREAD 10-32X2 [2.EA]	55	2991993	BRKT BTTM/BEARING FW ASSEMBLY	91	2372100	SCREW-8-18 X 5/8 THD* SS [2.EA]
20	830-094	THRU BOLT 12-24X10.31 [2.EA]	56	2772352	EYELET-ROPE KIT	92	2383407	SCREW-10-24 X 2" PPH ZINC
21	973-025	SPACER- BRUSH PLATE [2.EA]	57	2263402	SCREW 1/4-20 K 3/4" ZINC	93	2383124	NUT-10-24 NYLOC ZINC
22	990-051	WASHER- STEEL	58	2263404	SCREW-1/4-20X2 1/4 SHCP [2.EA]	94	2301310	SCREW-8-18 X 1/2 SS [2.EA]
23	990-052	WASHER- NYLATRON	59	2261525	SPRING-SLEEVE UPPER	95	2150400	PULL-GRIP
24	2317036	MTR ASSEMBLY 24V 4" VARS	60	2261535	SPRING SLEEVE, LOWER	96	2151700	WASHER-EYE SHAFT .562 OD
25	2032058	TUBE- COMPOSITE 42"	61	2264702	INSERT-TUBE (2 PER) B.MNT [2.EA]	■	2994830	BAG ASSEMBLY-MAXXUM
■	1378129	PROPELLER KIT	62	2262704	SPRING, BOWGUARD, HAND CT	*97	2263431	SCREW 1/4-20 X 3.5 PPH [6.EA]
26	2331120	PROPELLER -W.WEDGE	63	2011365	SCREW-COLLAR/NEW KNOB	*99	2261713	WASHER-1/4 FLAT SS [6.EA]
27	2091701	WASHER-PROP LARGE)	64	2031520	COLLAR-DEPTH W/O INSERT	*100	2263103	NUT-1/4-20 NYLOCK-JAM SS [6.EA]
28	2093101	NUT-PROP,NYLOC LARGE MAX101	65	2011365	SCREW-COLLAR/NEW KNOB	102	2330600	LEADWIRE 10GA. RINGS
29	2092600	PIN-DRIVE SS	66	2302743	SPRING-DETENT HANDLE-TILT	103	2262607	PIN-CLEVIS ZP MAXXUM BWGD
■	2771866	MOUNT, BOW ASSEMBLY W/BOWGRD	67	2303412	SCREW-6-20~X 5/8 SELF TAP [6.EA]	104	2260801	CLIP- SPRING ZP MAX BG
33	2264241	ARM-UPPER FW,STD	68	2332900	STRAIN RELIEF-C.CORD/C.BX	105	2262605	PIN- BWGRD UPPER THREADED ZP
34	2293501	BUSHING, STAINLESS STEEL [4.EA]	69	2303001	RING-PIG LOXIT HILL #2	106	9908236	WASHER- 1/4 FLAT ZINK [2.EA]
35	2263500	BOLT, SHOULDER MAXXUM [2.EA]	70	2062593	CONTROL BOX,FW, .875 BORE, ZNC	107	2223100	NUT-TENSION 5/16-18 SS [2.EA]

**Seal & Oring Kit P/N 2889460

* This item is part of an assembly.This item cannot be sold separately due to machining and /or assembly that is required.

P/N 2265001 REV J 7-01

MAXXUM 74/H Wiring Diagram

