

MAXXUM 74 (& SONAR) - 42"

74 LBS THRUST

24 VOLT

42" OR 36" SHAFT

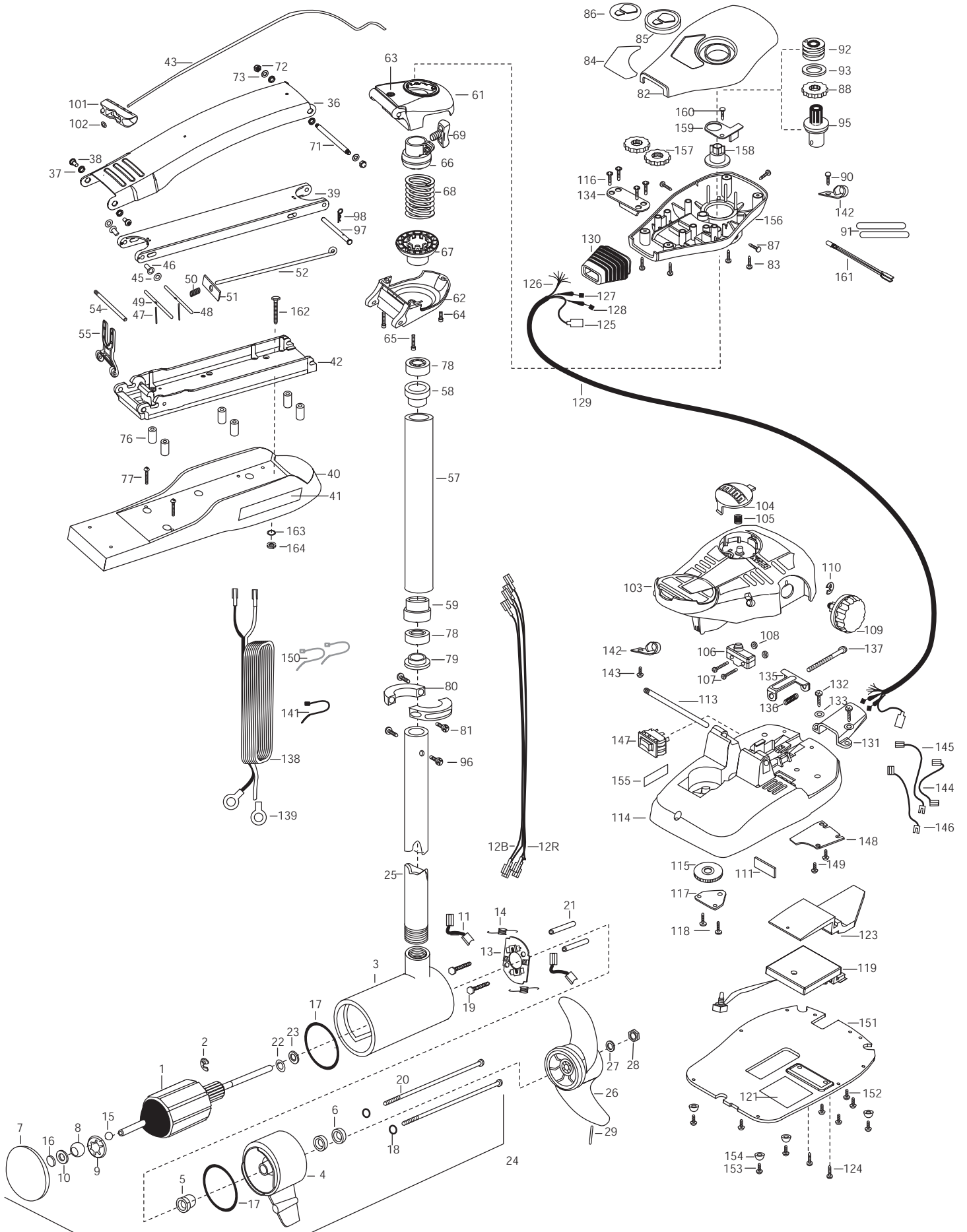

1	2-100-103	ARMATURE ASSEMBLY 24V 4"	55	2293811	YOKE,MAX MNT-POLYPROPYLENE	110	2263000	E-RING TRU-ARC#5133-43
2	788-040	RETAINING RING	■	2772012	TUBE W/BEARING RACE ASSEMBLY 42"	*111	2266413	PLATE -TENSION SCREW FTPTD.
3	92-200-170	HOUSING ASSEMBLY CENTER 4.0- SONAR		2772015	TUBE W/BEARING RACE ASSEMBLY 36"	113	2260511	PIN-PIVOT A/T PT PDL
4	2-300-160	BRUSH END HOUSING ASSEMBLY	57	2272069	TUBE -OUTER 21" 4 HOLES [FOR 42"]	114	2774550	FT PEDAL BASE/PIN ASSEMBLY
5	144-017	BEARING- FLANGE (SERVICE ONLY)		2272066	TUBE -OUTER 18" 4 HOLES [FOR 36"]	115	2262301	PULLEY- FOOT PEDAL
6	880-025	SEAL [2.EA]	58	2266260	BEARING RACE-(565T)	116	2223430	SCREW- 8X3/4 PPH TYPE 25 SS [4.EA]
7	92-400-170	PLAIN END HOUSING ASSEMBLY- SONAR	59	2266220	BEARING RACE-STEEL	117	2266400	COVER-PULLEY STAMPING
	2-400-160	PLAIN END HOUSING ASSEMBLY	■	2991869	BOWGUARD ASSEMBLY-FT CTRL,MAX	118	2301310	SCREW-8-18 X 1/2 SS [2.EA]
8	144-021	BEARING SPHERICAL	61	2772315	BRACKET BASE TOP/EYELETASSEMBLY	119	2264008	CONTROL BOARD ASSEMBLY 24V MAX
9	784-025	BEARING RETAINER	62	2991999	BRKT BOTTOM/BEARING FW ASSEMBLY	121	2365107	INSULATING PAD 2.3 X 3.2
10	991-040	WASHER- FELT	63	2772352	EYELET KIT -ROPE	123	2264018	HEAT SINK, MACH, MAX PT
11	186-094	BRUSH [2.EA]	64	2263402	SCREW 1/4-20 X 3/4 ZINC	124	2263447	SCREW, 8-32 X 1 [2.EA]
12B	640-013	BRUSH LEAD BLK 10 AWG 51-1/2	65	2263404	SCREW-1/4-20X2-1/4 SHCP [2.EA]	125	2211400	EXTENSION CABLE- SONAR
12R	640-117	BRUSH LEAD RED 10 AWG 53	66	2261525	SPRING-SLEEVE UPPER	126	2261219	WIRE HARNESS AT & MAX 82.5
13	738-004	BRUSH PLATE 4"	67	2261535	SPRING SLEEVE, LOWER	127	2267500	CABLE ASSEMBLY-RIGHT 5'
14	975-041	SPRING- TORSION [2.EA]	68	2262706	SPRING, BOWGUARD, NIK PL	128	2267510	CABLE ASSEMBLY-LEFT 5'
15	116-025	BALL- STEEL	69	2011365	SCREW-COLLAR/NEW KNOB	129	2265430	CABLE JACKET 5'
16	303-043	THRUST DISC	71	2262605	PIN- THREADED	130	2265110	BOOT-CONTROL BOX
17	701-043	O-RING [2.EA]	72	2263100	NUT- NYLOC [2.EA]	131	2265115	BOOT-FOOT PEDAL BASE
18	701-009	O-RING —THRU BOLT [2.EA]	73	9908236	WASHER [2.EA]	132	2372100	SCREW-8-18 X 5/8 THD SS [2.EA]
19	830-027	SCREW -SELF THREAD 10-32X2 [2.EA]	■	2994832	BAG ASSEMBLY	133	2261714	WASHER-MAXXUM PT PDL [2.EA]
20	830-094	THRU BOLT 12-24X10.31 [2.EA]	*76	2261505	SPACER, MOTOR REST [6.EA]	134	2261901	BRACKET-CONDUIT AT/MAX
21	973-025	SPACER- BRUSH PLATE [2.EA]	*77	2263434	SCREW, 8-18 X 1 PPH SS [2.EA]	135	2263210	BRACKET-CONDUIT ADJUSTMENT
22	990-051	WASHER- STEEL	78	2266000	BEARING BALL-STEEL	136	2262720	SPRING-CONDUIT
23	990-052	WASHER- NYLATRON	79	2266115	BEARING CONE	137	2263463	SCREW-1/4-20 X 2 STL PPH
24	2317036 / 2327032	MOTOR ASSEMBLY PLAIN / SONAR	80	2771617	COLLAR HALF-ZINC-2 PER- KIT	138	2261227	LEADWIRE VARIABLE
25	2032061	TUBE COMP W/CSK HOLE 43-3/4	81	2263452	SCREW-1/4-20 X 3/4 SHCS SS [2.EA]	139	2020700	TERMINAL RING, 3/8 [2.EA]
	2032062	TUBE COMP W/CSK HOLE 36"	82	2260283	CONTROL BOX COVER-MAXXUM	141	2256300	TIE WRAP-5.5 BLACK
■	1378129	PROPELLER KIT	83	2372100	SCREW-8-18 X 5/8 THD [4.EA]	142	2263201	CLAMP WIRE HARNESS MICRO [2.EA]
26	2331120	PROPELLER W.WEDGE HP&RT	84	2265532	DECAL COVER, MAXXUM 74	143	2332103	SCREW-6-20 X 3/8 THD SS
27	2091701	WASHER-PROP LARGE	85	2260150	POINTER DISC TRNSLCNT RED	144	2260316	CONNECTING WIRE VAR.SPD
28	2093101	NUT-PROP NYLOCK SS	86	2265800	DECAL-INDICATOR	145	2260312	WIRE,BLK W/WHT STRP 19 1/2
29	2092600	PIN-DRIVE SS	87	2053414	SCREW-#8-32 X 1/2 TRI-LOBE [3.EA]	146	2260323	WIRE,BLK W/GRN STP VARIAB
■	2771840	MOUNT,BOW ASSEMBLY, FW STD W/BG	88	2267800	GEAR-INDICATOR	147	2254031	SWITCH-MOM/OFF/COM
36	2264241	ARM UPPER-FW STD	90	2301310	SCREW-8-18 X 1/2 SS	148	2266412	SWITCH PLATE, PT PEDAL
37	2293501	BUSHING, STAINLESS STEEL [4.EA]	91	2355410	SHRINK TUBE-3/8 OD X 2- [2.EA]	149	2332103	SCREW-6-20 X 3/8 THD SS [2.EA]
38	2263500	BOLT, SHOULDER MAXXUM [2.EA]	92	2232360	PULLEY-CABLE DRUM	150	2256301	TIE WRAP-5.5 WHITE [2.EA]
39	2774315	ARM-LOWER ASSEMBLY,STD,FW,EXT	93	2261730	WASHER-NYLON	151	2264510	BOTTOM PLATE, MAXXUM PT
40	2263912	MOTOR REST STD MAXXUM	95	2996246	PINION/RACE ASSEMBLY	152	9953104	SCREW-8 X 1/2 PPH SS [5.EA]
41	2265514	DECAL-MAXXUM,MOTOR REST [2.EA]	96	2263410	SCREW-8-32 X 5/16 ZN PL [2.EA]	153	2263455	SCREW #12 [4.EA]
42	2773987	BOWPLATE- FW STD MACH/INSERT	97	2262607	PIN- CLEVIS ZN	154	2265126	BUMPER [4.EA]
43	2251601	ROPE 40" MAXXUM MOUNT	98	2260801	SPRING CLIP ZN	155	2266610	DECAL-ON/OFF SWITCH
45	2261708	WASHER-3/8X1/2X.016 [2.EA]	101	2150400	PULL-GRIP	156	2262535	CONTROL BOX-PLASTIC AT'S
46	2236000	BEARING NYLINER- [2.EA]	102	2151700	WASHER-EYE SHAFT .562 OD	157	2267800	GEAR-INDICATOR [2.EA]
47	2152610	SPRING-PIN LOCKBAR [2.EA]	103	2790002	FOOT PEDAL/PLUG ASSEMBLY	158	2262220	INDICATOR-DRIVE
48	2233600	LOCK BAR- BOW MOUNT	104	2263700	PUSH-BUTTON FOOT PEDAL	159	2261905	BRACKET/INDICATOR
49	2233602	LOCK BAR- REAR ZINC	105	2302732	SPRING-LOWER PEDAL SS	160	2301310	SCREW-8-18 X 1/2 SS
50	2152700	SPRING-LOCKBAR CAD.PLT	106	2264023	SWITCH-SEALED ASSEMBLY	161	2264015	LIGHT/INDICATOR
51	2262703	SPRING STOP	107	2262114	SCREW-MOUNTING/SWITCH [2.EA]	■	2994830	BAG ASSEMBLY-MAXXUM
52	2153602	EYE SHAFT-2LOCKBAR STD-PLTD	108	2233100	NUT-SWITCH MOUNT [2.EA]	*162	2263431	SCREW 1/4-20 X 3.5 PPH [6.EA]
54	2260506	HINGE-PIN HEADLESS ZINC	109	2260160	KNOB-SPEED CONTROL VAR	*163	2261713	WASHER-1/4 FLAT S/S [6.EA]

**Seal & Oring Kit P/N 2889460

* This item is part of an assembly. This item cannot be sold separately due to machining and /or assembly that is required.

P/N 2264945 REV.F

7-01

MAXXUM 74 Wiring Diagram

