

MAXXUM 65/SC - 42"

65 lbs Thrust

24 Volt

42" SHAFT

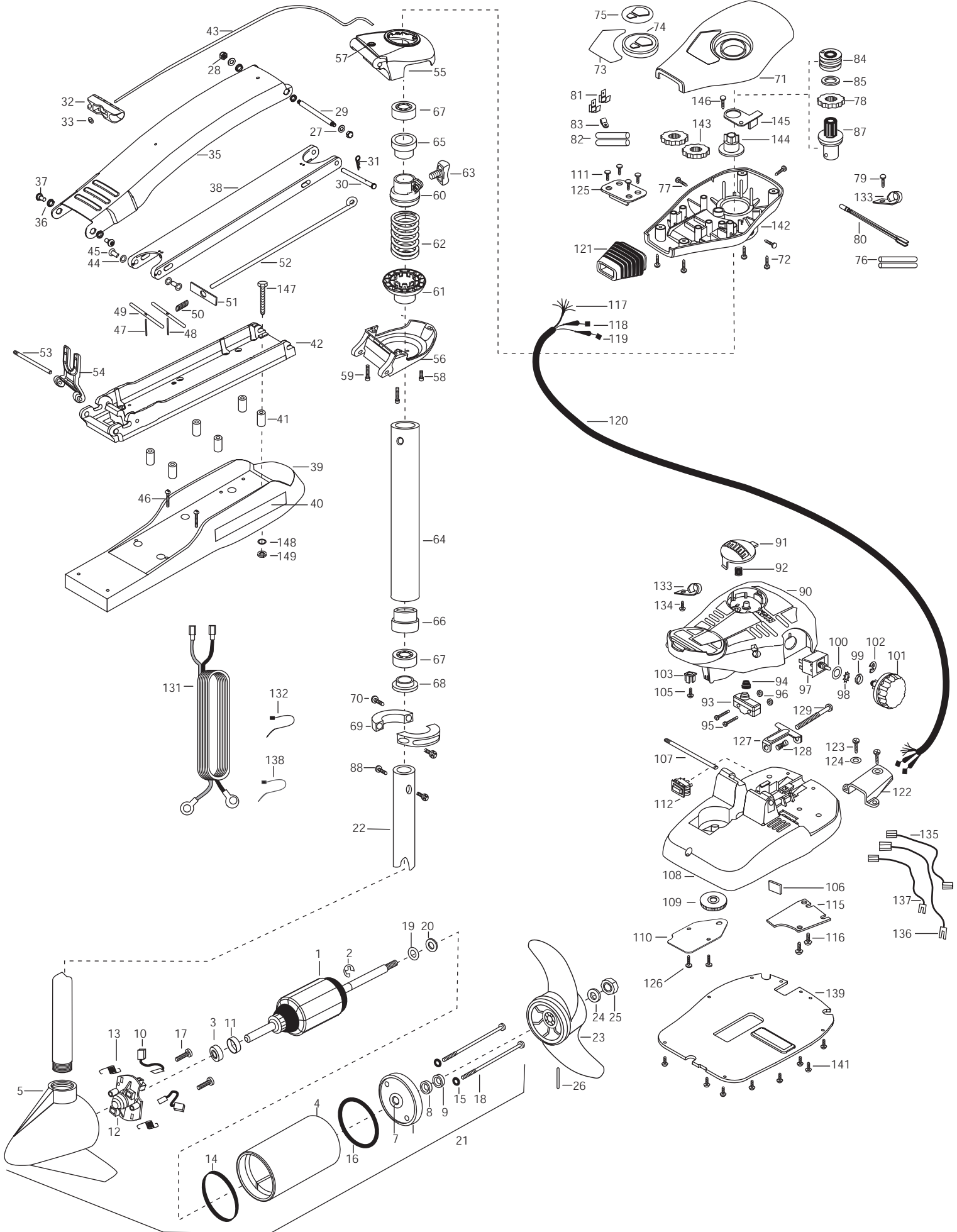

1	92-100-009	ARMATURE ASSEMBLY 24V 3.625 5SPC 65#	50	2152700	SPRING-LOCKBAR CAD.PLTD	100	2261715	SPACER-SWITCH 5 SP MODELS
2	788-015	RETAINING RING	51	2262703	SPRING STOP	101	2260170	KNOB-SPEED CONTROL (5 SPD)
3	140-010	BALL BEARING	52	2153602	EYE SHAFT-2LOCKBAR STD-PL	102	2263000	E-RING TRU-ARC#5133-43
4	431-005	CENTER HOUSING ASSEMBLY 3.625 FW TXT	53	2260506	HINGE-PIN HEADLESS ZINC	103	2260730	CONNECTOR 1/4 MALE TAB OD
5	2-300-039	BRUSH END HOUSING ASSEMBLY 3.62 SPCO	54	2293811	YOKE,MAX MNT-POLYPROPYLENE	105	2332103	SCREW-6-20 X 3/8" THD SS
6	2-400-101	PLAIN END HOUSING ASSEMBLY	■	2991869	BOWGUARD ASSEMBLY	106	2266413	TENSION SCREW PLATE FTPED
7	144-049	BEARING - FLANGE (SERVICE ONLY)	55	2772315	BRACKET BASE TOP/EYELET ASSEMBLY	107	2260511	PIN-PIVOT A/T FT PDL
8	880-003	**SEAL	56	2991999	BRKT BTTM/BEARING FW ASSEMBLY	108	2774550	FT PED BASE/PIN ASSEMBLY
9	880-006	**SEAL WITH SHIELD	57	2772352	EYELET KIT	109	2262301	PULLEY- FOOT PEDAL
10	188-036	BRUSH ASSEMBLY [2.EA]	58	2263402	SCREW 1/4-20 X 3/4" ZINC	110	2266401	COVER-PULLEY STAMPING
11	725-050	BRUSH RETENTION- PAPER TUBE	59	2263404	SCREW-1/4-20X2 1/4" SHCP SS [2.EA]	111	2223430	SCREW- #8 X3/4 SS PPH TYPE 25 [4.EA]
12	738-036	BRUSH PLATE W/HOLDER	60	2261525	SPRING-SLEEVE UPPER	112	2254031	SWITCH-M0M/OFF/CON
13	975-040	SPRING - TORSION [2.EA]	61	2261535	SPRING SLEEVE, LOWER	115	2266412	SWITCH PLATE, FT PEDAL
14	337-036	**GASKET	62	2262706	SPRING, BOWGUARD, NIK PL	116	2332103	SCREW-6-20 X 3/8 THD SS [2.EA]
15	701-008	**O-RING, THRU-BOLT [2.EA]	63	2011365	SCREW- COLLAR/NEW KNOB	117	2261208	WIRE HARNESS, A/T FT. PHD
16	701-081	**O-RING	■	2772012	TUBE W/BEARING RACE ASSEMBLY	118	2267500	CABLE ASSY-RIGHT (5')
17	830-007	SCREW-8-32 [2.EA]	64	2272069	TUBE OUTER-21" 4 HOLES	119	2267510	CABLE ASSY-LEFT (5')
18	830-008	THRU-BOLT 10-32X9.2" [2.EA]	65	2266260	BEARING RACE	120	2265430	CABLE JACKET (5')
19	990-067	WASHER- STEEL THRUST	66	2266220	BEARING RACE-STEEL	121	2265110	BOOT-CONTROL BOX
20	990-070	WASHER - NYLATRON [2.EA]	67	2266000	BEARING BALL-STEEL [2.EA]	122	2265115	BOOT-FOOT PEDAL BASE
21	2098034	MOTOR ASSEMBLY 24V 3.625 5SPC FW 65#	68	2266115	BEARING CONE	123	2372100	SCREW-8-18 X 5/8 THD SS [2.EA]
22	2032061	TUBE (COMP) W/CSK HOLE-43 3/4"	69	2771617	COLLAR HALF-ZINC- 2 PER KIT	124	2261714	WASHER-MAXXUM FT PDL [2.EA]
■	1378122	PROP KIT	70	2263452	SCREW-1/4-20 X 3/4" SHCS [2.EA]	125	2261901	BRACKET-CONDUIT
23	2091150	PROPELLER (W.WEDGE)	71	2260283	CONTROL BOX COVER -MAXXUM	126	2301310	SCREW-8-18 X 1/2 SS [2.EA]
24	2151726	WASHER-5/16 STD SS	72	2372100	SCREW-8-18 X 5/8" THD SS [4.EA]	127	2263210	BRACKET-CONDUIT ADJUSTMEN
25	2053101	NUT-PROP,NYLOC (MED) 5/16 SS	73	2265629	DECAL-COVER MAX65/SC	128	2262720	SPRING-CONDUIT AD
26	2092600	PIN-DRIVE (95-4HP'S) SS	74	2260150	POINTER DISC SHORT RED	129	2263463	SCREW-1/4-20 X 2" STL PPH
27	9008236	WASHER 1/4 FLAT ZINC [4.EA]	75	2265800	DECAL-INDICATOR	131	2261225	LEADWIRE 24V 10GA. RING
28	2223100	NUT- TENSION 5/16-18 SS [2 .EA]	76	2375400	SHRINK TUBE-1/4OD X 1-3/4" [2.EA]	132	2256300	TIE WRAP-5.5" BLACK
29	2262605	PIN- BWGRD UPPER THREADED	77	2053414	SCREW-#8-32 X 1/2" TRI-LOBE [3.EA]	133	2263201	CLAMP WIRE HARNESS MICRO [2.EA]
30	2262607	CLEVIS PIN ZP MAXXUM BWGRD	78	2267800	GEAR-INDICATOR	134	2332103	SCREW-6-20 X 3/8 THDT SS
31	2260801	SPRING CLIP	79	2301310	SCREW-8-18 X 1/2" SS	135	2260301	CONNECTING WIRE (SWITCH)
32	2150400	PULL-GRIP	80	2264019	LIGHT/INDICATOR MAX65/SC	136	2260312	WIRE,BLK W/WHT STRP 19 1/2
33	2151700	WASHER-EYE SHAFT(.562 OD)	81	2020713	TERMINAL-ADAPTOR, MAX [2.EA]	137	2260322	WIRE,BLK W/BLUE STRP-12"
■	2771840	MOUNT, BOW ASSEMBLY, FW STD	82	2335400	SHRINK TUBE-1/2 OD X 2" [2.EA]	138	2256301	TIE WRAP-5.5" WHITE
35	2264241	ARM-UPPER FW,STD	83	2052511	CABLE CLAMP, 1/4" VANTAGE	139	2266414	BOTTOM PLATE MAX FOOT PED
36	2293501	BUSHING, STAINLESS STEEL [4.EA]	84	2232360	PULLEY-CABLE DRUM	141	9953104	SCREW-8 X 1/2" SS [8.EA]
37	2263500	BOLT- SHOULDER (MAXXUM) [2.EA]	85	2261730	WASHER-NYLON A/T CON B	142	2262535	CONTROL BOX-PLASTIC
38	2994307	ARM-LOWER ASSEMBLY,STD,FW,EXT	87	2776203	PINION/RACE ASSEMBLY	143	2267800	GEAR-INDICATOR [2.EA]
39	2263912	MOTOR REST STD MAXXUM	88	2263410	SCREW-8-32 X 5/16" ZN PL [2.EA]	144	2262220	INDICATOR-DRIVE
40	2265514	DECAL-MAXXUM,MOTOR REST [2.EA]	90	2790002	FOOT PEDAL/PLUG ASSEMBLY (AT)	145	2261905	BRACKET/INDICATOR
41	2261505	SPACER, MOTOR REST [6.EA]	91	2263700	PUSH-BUTTON FOOT PEDAL	146	2301310	SCREW-8-18 X 1/2" SS
42	2773987	BOWPLATE,STD FW-MACH/INSERT	92	2302732	SPRING-LOWER PEDAL SS	■	2994830	BAG ASSEMBLY-MAXXUM
43	2251601	ROPE (40"), MAXXUM MOUNT	93	2264020	SWITCH MOMENTARY	*147	2263431	SCREW 1/4-20 X 3.5" PPH [6.EA]
44	2261708	WASHER-3/8X1/2X.010" SS [2.EA]	94	2265140	BOOT-MICROSWITCH	*148	2261713	WASHER-1/4 FLAT SS [6.EA]
45	2236000	BEARING NYLINER-[2.EA]	95	2262114	SCREW-MOUNTING/SWITCH [2.EA]	*149	2263103	NUT-1/4-20 NYLOCK-JAM SS [6.EA]
46	2263434	SCREW, 8-18 X 1" PPH SS [2.EA]	96	2233100	NUT-SWITCH MOUNT [2.EA]			
47	2152610	SPRING-PIN LOCKBAR [2.EA]	97	2264026	SWITCH-5 SPEED (ALL TERRAIN)			
48	2233600	LOCK BAR- BOW MOUNT	98	2261701	LOCKWASHER-STAR			
49	2233602	LOCK BAR, REAR - ZINC	99	2263105	NUT-HEX			

**Seal & Oring Kit P/N 2888460

* This item is part of an assembly. This item cannot be sold separately due to machining and /or assembly that is required.

P/N 2274901 REV.A 6-02

