

MAXXUM 65 (& SONAR) - 52" & 62"

65 lbs Thrust

24 Volt

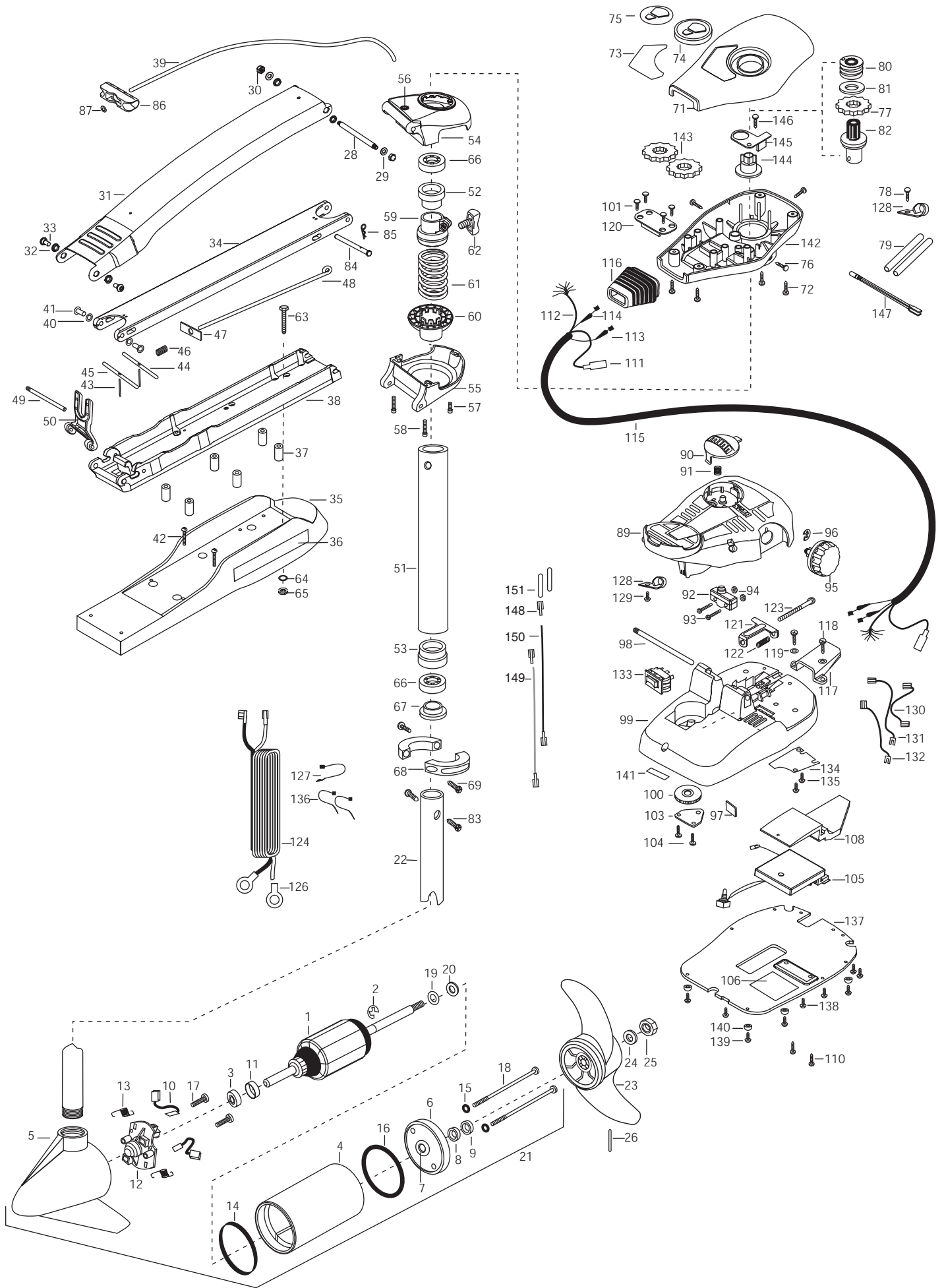

1	92-100-009	ARMATURE ASSEMBLY	46	2152700	SPRING- LOCKBAR CAD.PLTD	94	2233100	NUT- SWITCH MOUNT [2.EA]
2	788-015	RETAINING RING	47	2262703	SPRING STOP- MAXXUM	95	2260160	KNOB- SPEED CONTROL (VAR)
3	140-010	BALL BEARING	48	2153604	EYE SHAFT- 2LOCKBAR LG PLTD	96	2263000	E-RING THU-ARC
4	431-005	CENTER HOUSING ASSEMBLY	49	2260506	HINGE-PIN HEADLESS ZINC	97	2266413	TENSION SCREW PLATE FTPEDAL
5	9421-166	HOUSING BRUSH END 3.62 SONAR 52"	50	2293811	YOKE- MAKXUM MOUNT,POLYPROPYLENE	*98	2260511	PIN- PIVOT A/T FT PDL
	421-065	HOUSING BRUSH END 3.62 62"	■	2772016	TUBE W/BEARING RACE ASSEMBLY 52"	99	2774550	FT PEDAL BASE/PIN ASSEMBLY
6	2-400-101	PLAIN END HOUSING ASSEMBLY		2772014	TUBE W/BEARING RACE ASSEMBLY 62"	100	2262301	PULLEY- FOOT PEDAL
7	144-049	BEARING - FLANGE (SERVICE CENTER ONLY)	51	2272067	TUBE OUTER-24" 4 HOLES 48"-52"	101	2223430	SCREW- #8X3/4 PPH TYPE 25 SS [4.EA]
8	880-003	**SEAL		2272068	TUBE OUTER-34" 4 HOLES 62"	103	2266400	COVER- PULLEY
9	880-006	**SEAL WITH SHIELD	52	2266260	BEARING RACE	104	2301310	SCREW- 8-18 X 1/2 [4.EA]
10	188-036	BRUSH ASSEMBLY [2.EA]	53	2266220	BEARING RACE- STEEL	105	2264008	CNTROL BOARD ASSEMBLY 24V MAX65/FC
11	725-050	BRUSH RETENTION- PAPER TUBE	■	2991869	BOWGUARD ASSEMBLY- FT CTRL,FW 52"	106	2365107	INSULATING PAD (2.3X3.2)
12	738-036	BRUSH PLATE W/HOLDER		2991867	BOWGUARD ASSEMBLY- FT CTRL,FW 62"	108	2264018	HEAT SINK- MACH, MAX FTL
13	975-040	SPRING - TORSION [2.EA]	54	2772315	BRACKET BASE TOP/INSERT ASSEMBLY	110	2263447	SCREW- 8-32 X 1" [2.EA]
14	337-036	**GASKET	55	2991999	BRKT BOTTOM/BEARING FW ASSEMBLY 52"	111	2211400	EXTENSION CABLE- SONAR ONLY
15	701-008	**O-RING, THRU-BOLT [2.EA]		2991993	BRKT BOTTOM/BEARING FW ASSEMBLY 62"	112	2261219	WIRE HARNESS AT & MAX
16	701-081	**O-RING	56	2772352	EYELET- ROPE KIT	113	2267500	CABLE ASSEMBLY- RIGHT (5')
17	830-007	SCREW-8-32 [2.EA]	57	2263402	SCREW- 1/4-20 X 3/4" ZINC	114	2267510	CABLE ASSEMBLY- LEFT (5')
18	830-008	THRU-BOLT 10-32X9.2 [2.EA]	58	2263404	SCREW-1/4-20 X 2 1/4 SCHP SS [2.EA]	115	2265430	CABLE JACKET (5')
19	990-067	WASHER- STEEL THRUST	59	2261525	SPRING SLEEVE- UPPER	116	2265110	BOOT- CONTROL BOX
20	990-070	WASHER- NYLATRON [2.EA]	60	2261535	SPRING SLEEVE- LOWER	117	2265115	BOOT- FOOT PEDAL BASE
21	2108031	MOTOR ASSEMBLY 24V F/W 52" SONAR	61	2262712	SPRING- BOWGUARD, FC PAINTED	118	2372100	SCREW- 8-18X5/8 THD [2.EA]
	2098030	MOTOR ASSEMBLY 24V F/W 62"	62	2011365	SCREW- COLLAR/NEW KNOB	119	2261714	WASHER- MAXXUM FT PDL [2.EA]
	2098031	MOTOR ASSEMBLY 24V F/W 52"	■	2994830	BAG ASSEMBLY- MAXXUM	120	2261901	BRACKET- CONDUIT
22	2032067	TUBE- COMPOSITE 52" W/CSK HOLE	*63	2263431	SCREW- 1/4-20 X 3.5 PPH [6.EA]	121	2263210	BRACKET- CONDUIT ADJUST
	2032066	TUBE- COMPOSITE 62" W/CSK HOLE	*64	2261713	WASHER- 1/4 FLAT S/S [6.EA]	122	2262720	SPRING- CONDUIT ADJUST
	2032064	TUBE- COMPOSITE 48" W/CSK HOLE	*65	2263103	NUT- 1/4-20 NYLOCK-JAM SS [6.EA]	123	2266366	SCREW- 1/4-20X2" STL PPH
■	1378122	PROPELLER KIT	■	2994832	BAG ASSEMBLY- MAX101 62"	124	2261227	LEADWIRE- A/T VARIABLE
23	2091150	PROPELLER W.WEDGE	66	2266000	BEARING BALL- STEEL [2.EA]	126	2020700	TERMINAL RING- 3/8" [2.EA]
24	2151726	WASHER-5/16 SS	*67	2266115	BEARING CONE	127	2256300	TIE WRAP- 5.5' BLACK
25	2053101	NUT-PROP NYLOC	*68	2261622	COLLAR HALF- ALUM. [2.EA]	128	2263201	CLAMP WIRE HARNESS MICRO [2.EA]
26	2092600	PIN-DRIVE	*69	2263453	SCREW- 1/4-20X3/4 [2.EA]	129	2332103	SCREW- 6-20X3/8 THD (SS)
28	2262605	PIN- BWGRD UPPER THREADED ZP	71	2260283	CONTROL BOX COVER- MAXXUM	130	2260316	CONNECTING WIRE (VAR.SPD)
29	9908236	WASHER- 1/4 FLAT ZINC [2.EA]	72	2372100	SCREW- 8-18 X 5/8 THD [4.EA]	131	2260312	WIRE- BLK W/WHT STRP 19 -1/4"
30	2223100	NUT- TENSION 5/16-18 SS [2.EA]	73	2265620	DECAL- COVER MAX65/FC	132	2260323	WIRE- BLK W/GRN STP VARIABLE
■	2771869	MOUNT- BOW ASSEMBLY, LONG FW MAX	74	2260150	POINTER DISC TRNSLCNT RED	133	2254031	SWITCH- MOM/OFF/CON
	2771864	MOUNT- BOW ASSEMBLY, LONG FW MAX 62"	75	2265800	DECAL- INDICATOR	134	2266412	SWITCH PLATE- FT PEDAL
31	2264246	ARM-UPPER LONG FW	76	2053414	SCREW- 8-32 X 1/2 TRI-LOBE [3. EA]	135	2332103	SCREW- 6-20X3/8 THD SS [2.EA]
32	2293501	BUSHING- STAINLESS STEEL [4.EA]	77	2267800	GEAR- INDICATOR	136	2256301	TIE WRAP- 5.5" WHITE [2.EA]
33	2263500	BOLT- SHOULDER MAXXUM [2.EA]	78	2301310	SCREW- 8-18 X 1/2	137	2774510	BOTTOM PLATE- MAXXUM FT
34	2774317	ARM-LOWER ASSEMBLY, LONG,FW,EXTRA [INCLUDES 39, 43-47, 86,87]	79	2355410	SHRINK TUBE- 3/8 OD X 2" [2.EA]	138	2372100	SCREW-8 X 1/2" (SS) [5.EA]
35	2263913	MOTOR REST LONG FW	80	2232360	PULLEY- CABLE DRUM	139	2263455	SCREW- #12-14X1/2 THR FRM [4.EA]
36	2265514	DECAL- MAXXUM MOTOR REST [2.EA]	81	2261730	WASHER- NYLON A/T CON	140	2265126	BUMPER PAD- FOOT PEDAL [4.EA]
37	2261505	SPACER- MOTOR REST [6.EA]	82	2996246	TOP BEARING RACE /PINION DRIVE	141	2266610	DECAL- ON/OFF SWITCH
38	2773986	BOWPLATE- W/INSERT	83	2263410	SCREW- 8-32 X 5/16 [2.EA]	142	2262535	CONTROL BOX- PLASTIC
39	2251601	ROPE (40"), MAXXUM MOUNT	84	2262607	PIN- CLEVIS ZP MAXXUM BWGRD	143	2267800	GEAR- INDICATOR [2.EA]
40	2261708	WASHER- 3/8X1/2X.010 SS [2.EA]	85	2260801	CLIP- SPRING ZP MAX BG	144	2262220	INDICATOR- DRIVE
41	2236000	BEARING NYLINER [2.EA]	86	2150400	PULL- GRIP	145	2261905	BRACKET/INDICATOR
42	2263434	SCREW, 8-18X1" PPH [2.EA]	87	2151700	WASHER- EYE SHAFT(.562 OD)	146	2301310	SCREW- 8-18X1/2"
43	2152610	SPRING- PIN LOCKBAR [2.EA]	89	2790002	FOOT PEDAL/PLUG ASSEMBLY	147	2264015	LIGHT/INDICATOR
44	2233600	LOCK BAR- BOW MOUNT	90	2263700	PUSH- BUTTON FOOT PEDAL	148	2030710	CONNECTOR BUTT [2.EA]
45	2233602	LOCK BAR REAR - ZINC	91	2302732	SPRING- LOWER PEDAL	149	2030317	WIRE EXTENSION 18" RED
			92	2264023	SWITCH- SEALED ASSEMBLY	150	2030316	WIRE EXTENSION 18" BLACK
			93	2262114	SCREW- MOUNTING/SWITCH [2.EA]	151	2375400	SHRINK TUBE 1/4ODX1-3/4 [2.EA]

**Seal & Oring Kit P/N 2888460

* This item is part of an assembly. This item cannot be sold separately due to machining and /or assembly that is required.

P/N 2264944 REV. E 6-02

MAXXUM 65 Wiring Diagram

