

MAXXUM 101 - 52" & 62"

101 lbs Thrust

36 Volt

52 & 62" SHAFT

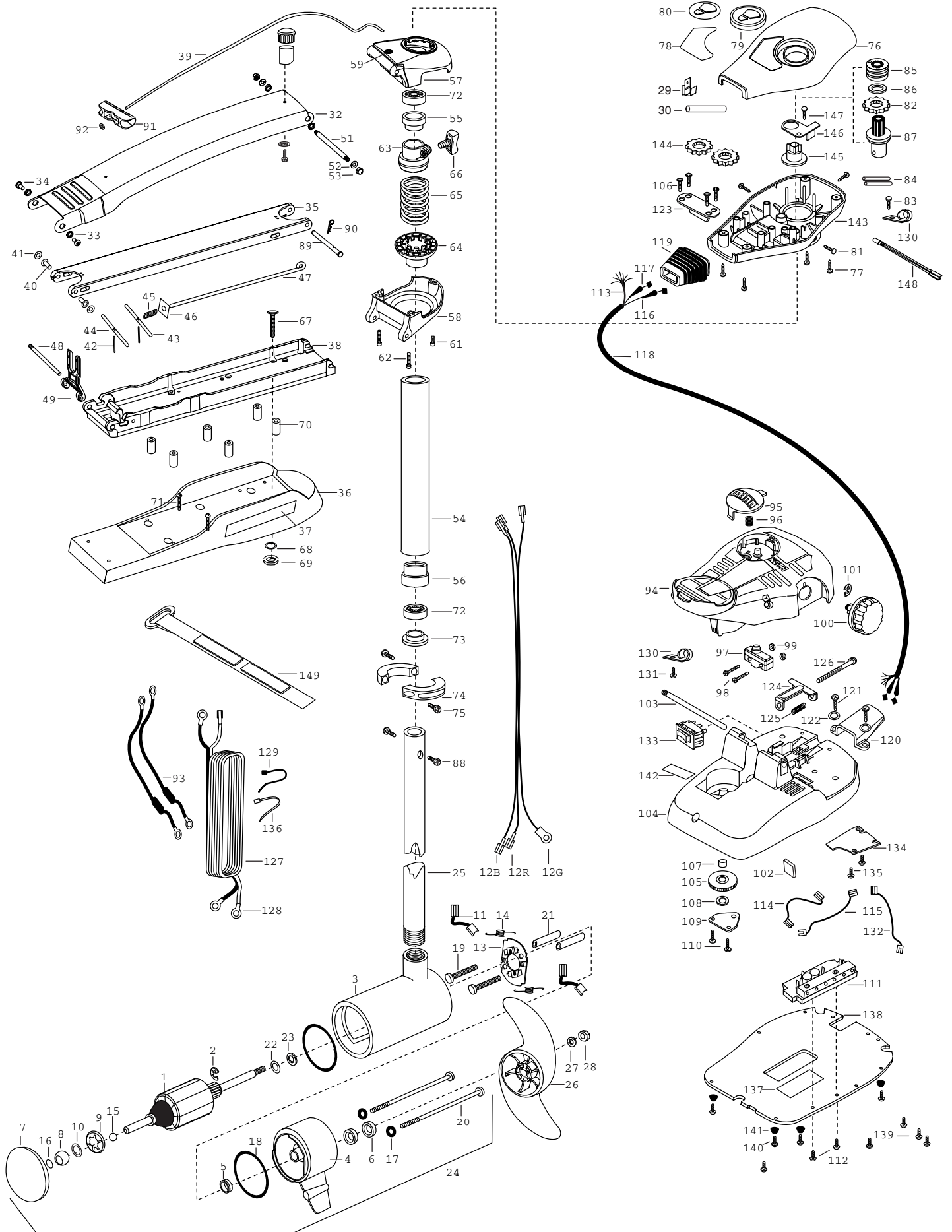

1	2-100-110	ARMATURE ASSEMBLY 36V 4 VARS FW 101#	52	9908236	WASHER 1/4 FLAT ZINC [2.EA]	103	2260511	PIN-PIVOT A/T FT PDL
2	788-040	RETAINING RING	53	2223100	NUT-TENSION 5/16-18 SS [2.EA]	104	2992102	FOOT PEDAL BASE/PIN ASSEMBLY
3	431-110	CENTER HOUSING ASSEMBLY 4.0 FW TXT MAX	■	2772016	TUBE W/BEARING RACE ASSEMBLY 52"	105	2262300	PULLEY FOOT PEDAL
4	2-300-160	BRUSH END HOUSING ASSEMBLY 4.0 FW TXT		2772014	TUBE W/BEARING RACE ASSEMBLY 62"	106	2223430	SCREW- #8 X3/4" PPH TYPE 25 SS [4.EA]
5	144-017	BEARING -FLANGE (SERVICE ONLY)	54	2272067	TUBE OUTER -24" 4 HOLES 52"	107	2260000	BEARING-PULLEY
6	880-025	**SEAL [2.EA]		2272068	TUBE OUTER -34" 4 HOLES 62"	108	2261705	WASHER-NYLATRON A/T
7	2-400-160	PLAIN END HOUSING ASSEMBLY 4.0	55	2266260	BEARING RACE- 565T	109	2266400	COVER-PULLEY STAMPING
8	144-021	BEARING -SPHERICAL	56	2266220	BEARING RACE-STEEL	110	2301310	SCREW-8-18 X 1/2" SS [2.EA]
9	784-025	BEARING RETAINER	■	2991867	BOWGUARD ASSEMBLY-FT CTRL,MAX	111	2264012	CONTROL BOARD ASSEMBLY- MAX101
10	991-040	FELT WASHER	57	2772315	BRACKET BASE TOP/EYELET ASSEMBLY	112	2053414	SCREW 8-32 X 1/2 TRI-LOBE [2.EA]
11	188-094	BRUSH 4"W/TERMINAL [2.EA]	58	2771993	BRACKET BOTTOM/BEARING ASSEMBLY	113	2261218	WIRE HARNESS MAX 101
12B	640-017	BRUSH WIRE- BLACK 10 AWG 61 XLP	59	2772352	EYELET-ROPE KIT	114	2260325	WIRE,BLK W/GRN STRIPE 11 1/4"
12R	640-121	BRUSH WIRE- RED 10 AWG 62-1/2	61	2263402	SCREW 1/4-20 X 3/4" ZINC	115	2260326	WIRE,RED W/YEL STRIPE 16 1/2"
12G	640-303	GROUND WIRE- GREEN 10 AWG 61	62	2263404	SCREW, 1/4-20 X 2-1/4" SHCP [2.EA]	116	2267500	CABLE ASSEMBLY-RIGHT 5'
13	738-004	BRUSH PLATE - 4" TERMINAL	63	2261525	SPRING-SLEEVE UPPER	117	2267510	CABLE ASSEMBLY-LEFT 5'
14	975-041	SPRING -TORSION [2.EA]	64	2261535	SPRING SLEEVE, LOWER	118	2265430	CABLE JACKET 5'
15	116-025	BALL-STEEL	65	2262706	SPRING, BOWGUARD, NIK	119	2265110	BOOT-CONTROL BOX
16	303-043	THRUST DISC- METAL	66	2011365	SCREW-COLLAR/NEW KNOB	120	2265115	BOOT-FOOT PEDAL BASE
17	701-009	**O-RING -THRU BOLT [2.EA]	■	2994830	BAG ASSEMBLY-MAXXUM	121	2372100	SCREW-8-18 X 5/8",THDT [2.EA]
18	701-043	**O-RING (2 REQ'D)	*67	2263431	SCREW 1/4-20 X 3.5" PPH [6.EA]	122	2261714	WASHER-MAXXUM FT PDL [2.EA]
19	830-027	SCREW -SELF TREADED 10-32 X 2" [2.EA]	*68	2261713	WASHER-1/4" FLAT S/S [6.EA]	123	2261901	BRACKET-CONDUIT AT/MAX
20	830-096	THRU BOLT 12-24 X 11.56" SS [2.EA]	*69	2263103	NUT -NYLOCK JAM 1/4-20 S/S [6.EA]	124	2263210	BRACKET-CONDUIT ADJUST
21	973-025	SPACER -BRUSH PLATE [2.EA]	■	2994832	BAG ASSEMBLY	125	2262720	SPRING-CONDUIT ADJUST
22	990-051	WASHER-THRUST, STEEL	70	2261505	SPACER, MOTOR REST [6.EA]	126	2263463	SCREW-1/4-20 X 2" STL PPH
23	990-052	WASHER- NYLATRON	71	2263434	SCREW, 8-18 X 1" PPH [2.EA]	127	2261227	LEADWIRE A/T VARIABLE
24	2317051	MOTOR ASSEMBLY 36V VARS TXT	72	2266000	BEARING, BALL-STEEL [2.EA]	128	2020700	TERMINAL RING, 3/8" [2.EA]
25	2032068	TUBE (COMP) W/CSK HOLE 52"	73	2266115	BEARING CONE	129	2256300	TIE WRAP-5.5" BLACK
	2032066	TUBE (COMP) W/CSK HOLE 62"	74	2261619	COLLAR HALF-ZINC-2 PER	130	2263201	CLAMP WIRE HARNESS MICRO [2.EA]
■	1378130	PROPELLER KIT	75	2263452	SCREW- 1/4-20X3/4 SHCP SS [2.EA]	131	2332103	SCREW-6-20 X 3/8" THD
26	2331130	PROPELLER (W.WEDGE)	76	2260283	CONTROL BOX COVER-MAX	132	2260312	WIRE,BLK W/WHT STRIPE 19 1/4"
27	2091701	WASHER-PROP (LARGE) MAX 101	77	2372100	SCREW-8-18 X 5/8" THDT [4.EA]	133	2254031	SWITCH-MOM/OFF/COM
28	2093101	NUT-PROP (LARGE) MAX 101	78	2265539	DECAL COVER, MAXXUM 101	134	2266412	SWITCH PLATE, FT PEDAL
29	2020713	TERMINAL- ADAPTOR MAX50/S	79	2260150	POINTER DISC TRNSLCNT	135	2332103	SCREW-6-20 X 3/8" THD [2.EA]
30	2335400	SHRINK TUBE 1/4ODX2"	80	2265800	DECAL-INDICATOR	136	2256301	TIE WRAP-5.5' WHITE [2.EA]
■	2771864	MOUNT, BOW ASSEMBLY W/BWGRD FW MAX	81	2053414	SCREW-8-32 X 1/2" TRI-LOBE [3.EA]	137	2365109	INSULATING PAD 2.4 X 4.7"
32	2264246	ARM-UPPER FW LG	82	2267800	GEAR INDICATOR	138	2264511	BOTTOM PLATE, MAX 101
33	2293501	BUSHING, STAINLESS STEEL [4.EA]	83	2301310	SCREW-8-18 X 1/2" SS	139	9953104	SCREW-8 X 1/2" SS [5.EA]
34	2263500	BOLT, SHOULDER [2.EA]	84	2355410	SHRINK TUBE-3/8 OD X 2" [2.EA]	140	2263455	SCREW #12-14 X 1/2" THR FRM [4.EA]
35	2774317	ARM-LOWER ASSEMBLY, LG, FW EXTR	85	2232360	PULLEY-CABLE DRUM	141	2265126	BUMPER PAD, FOOT PEDAL [4.EA]
36	2263913	MOTOR REST LONG, MAXXUM	86	2261730	WASHER-NYLON A/T	142	2266610	DECAL-ON/OFF SWITCH
37	2265514	DECAL- MOTOR REST [2.EA]	87	2996246	TOP BEARING RACE /PINION DRIVE ASSEMBLY	143	2262535	CONTROL BOX-PLASTIC
38	2773986	BOWPLATE,LG FW /INSERT	88	2263410	SCREW-8-32 X 5/16" ZINC PLATE [2.EA]	144	2267800	GEAR-INDICATOR [2.EA]
39	2251601	ROPE 40" MAXXUM	89	2262607	PIN - CLEVIS ZP MAX BG	145	2262220	INDICATOR-DRIVE
40	2261708	WASHER-3/8 X 1/2 X.010" SS [2.EA]	90	2260801	CLIP-SPRING ZP MAX BG	146	2261905	BRACKET/INDICATOR
41	2236000	BEARING NYLINER [2.EA]	91	2150400	PULL-GRIP	147	2301310	SCREW-8-18 X 1/2" SS
42	2152610	SPRING-PIN (LOCKBAR) [2.EA]	92	2151700	WASHER-EYE SHAFT .562"	148	2264015	LIGHT/INDICATOR
43	2233600	LOCK BAR- (BOW MOUNT)	93	2998200	CIRCUIT BREAKER ASSEMBLY 36V-101 [2.EA]	149	2263802	STRAP- HOLD DOWN 30.5 VELCRO
44	2233602	LOCK BAR, REAR - ZINC	94	2790002	FOOT PEDAL/PLUG ASSEMBLY		NOT SHOWN--	62" SHAFT ONLY
45	2152700	SPRING -LOCKBAR	95	2263700	PUSH-BUTTON FOOT PEDAL		2030710	CONNECTOR BUTT [2.EA]
46	2262703	SPRING STOP	96	2302732	SPRING-LOWER PEDAL SS		2030711	CONNECTOR BUTT
47	2153604	EYE SHAFT -2LOCKBAR STD PLTD	97	2264023	SWITCH-SEALED ASSEMBLY		2030315	WIRE EXTENSION 18" GREEN
48	2260506	HINGE-PIN HEADLESS ZINC	98	2262114	SCREW-MOUNTING/SWITCH [2.EA]		2030317	WIRE EXTENSION 18" RED
49	2293811	YOKE, MAXXUM MOUNT POLYPROPYLENE	99	2233100	NUT-SWITCH MOUNT [2.EA]		2030316	WIRE EXTENSION 18" BLACK
■	2994833	BAG ASSEMBLY- MAXXUM STABILIZER	100	2260160	KNOB-SPEED CONTROL		2375400	SHRINK TUBE 1/4 X1-3/4" [2.EA]
51	2262605	PIN- BWGRD UPPER THREADED ZP	101	2263000	E-RING TRU-ARC#5133-43			
			102	2266413	TENSION SCREW PLATE FT			

