

ENGINE MOUNT (EM44 &EM54)

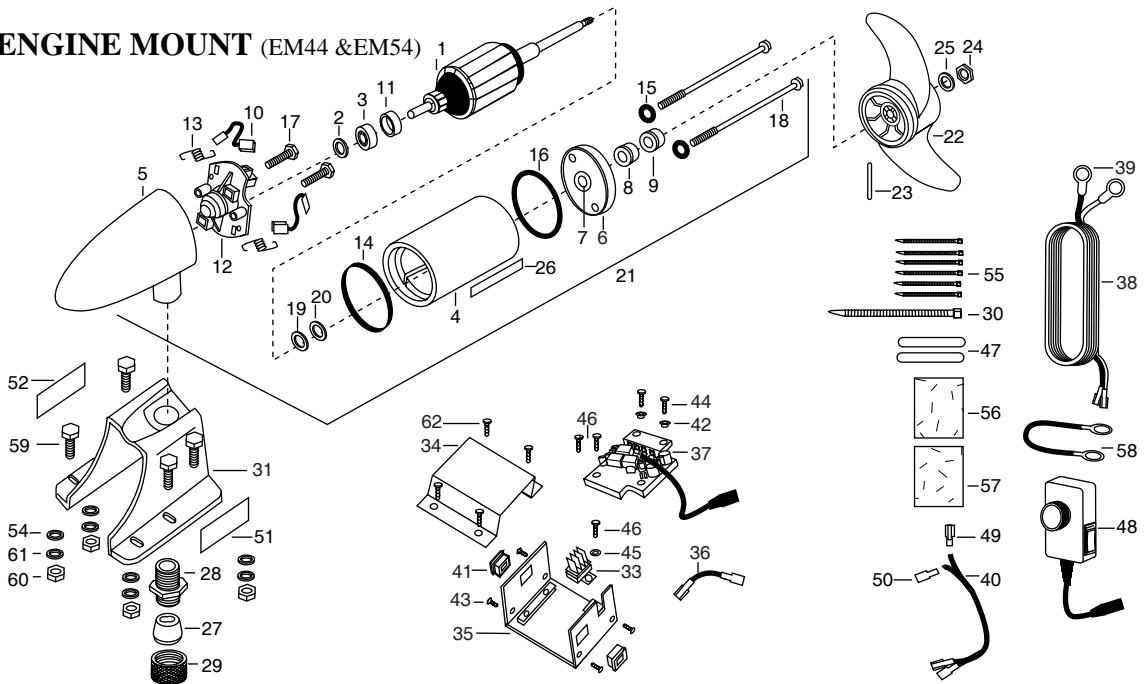

- | | | | | | |
|----|------------|------------------------------------|----|----------|------------------------------------|
| 1 | 92-100-105 | ARMATURE ASSEMBLY EM44 | 33 | 238-4007 | RELAY- MOTOR DISCONNECT |
| | 92-100-106 | ARMATURE ASSEMBLY EM54 | 34 | 238-6590 | HOUSING- COVER CONTROL MODULE |
| 2 | 991-036 | WASHER- FELT | 35 | 238-6592 | HOUSING- BASE CONTROL MODULE |
| 3 | 140-010 | BEARING- BALL | 36 | 202-0310 | CONNECTING WIRE 4-1/2" |
| 4 | 431-101 | CENTER HOUSING ASSEMBLY 3.62 | 37 | 238-4015 | CONTROL BOARD 12V |
| 5 | 421-001 | BRUSH END HOUSING 3.62 FW | | 238-4026 | CONTROL BOARD 24V |
| 6 | 2-400-101 | PLAIN END HOUSING ASSEMBLY | 38 | 209-0600 | LEADWIRE ASSEMBLY- 10 GA RINGS |
| 7 | 144-049 | BEARING- FLANGE | 39 | 202-0700 | WASHER-INSULATED TRANSF BAR [2.EA] |
| 8 | 880-003 | SEAL | 40 | 299-0603 | LEADWIRE/DISCONNECT ASSEMBLY |
| 9 | 880-006 | SEAL-W/SHIELD | 41 | 230-2921 | GROMMET- LEADWIRE/SPD CNTRL [2.EA] |
| 10 | 188-036 | BRUSH ASSEMBLY [2.EA] | 42 | 230-1710 | WASHER-INSULATED TRANSF BAR [2.EA] |
| 11 | 725-050 | PAPER TUBE- BRUSH RETENTION | 43 | 237-3426 | SCREW- 4- 40 X 1/4 PPH TCS [4.EA] |
| 12 | 738-036 | BRUSH PLATE W/HOLDER | 44 | 233-2101 | SCREW- 8- 32 X 1/2 SS [2.EA] |
| 13 | 975-040 | SPRING- TORSION [2.EA] | 45 | 238-1715 | LOCKWASHER- STAR #8 ZINC [4.EA] |
| 14 | 337-036 | GASKET | 46 | 237-3425 | SCREW- 8-32 X 5/16 PPHMS [3.EA] |
| 15 | 701-008 | O-RING- THRU BOLT [2.EA] | 47 | 230-5400 | SHRINK TUBE 3/8 OD X 1/[2.EA] |
| 16 | 701-081 | O-RING | 48 | 299-0210 | HAND CONTROLLER- MK |
| 17 | 830-007 | SCREW- #8-32 [2.EA] | 49 | 238-0300 | CONNECTOR- MALE .250 |
| 18 | 830-042 | THRU BOLT 10-32 X 8.83 [2.EA] | 50 | 238-0301 | CONNECTOR- FEMALE .250 |
| 19 | 990-067 | THRUST WASHER- STEEL | 51 | 238-5621 | DECAL- EM44 SIDE BRKT RIGHT |
| 20 | 990-070 | THRUST WASHER- NYLATRON [2.EA] | | 238-5623 | DECAL- EM54 SIDE BRKT RIGHT |
| 21 | 238-7003 | MOTOR ASSEMBLY EM44 12V VARS | | 238-5622 | DECAL- EM44 SIDE BRKT LEFT |
| | 238-7004 | MOTOR ASSEMBLY EM54 24V VARS | | 238-5624 | DECAL- EM54 SIDE BRKT LEFT |
| 22 | 209-1130 | PROPELLER- P WEDGE | ■ | 299-4823 | BAG ASSEMBLY 54EM |
| 23 | 209-2600 | PIN- DRIVE | | 299-4822 | BAG ASSEMBLY 44EM |
| 24 | 205-3101 | NUT- PROP NYLOCK 5/16 SS | 54 | 215 1726 | WASHER 5/16 STD SS [4.EA] |
| 25 | 215-1726 | WASHER 5/16 STD SS | 55 | 225-6300 | TIE WRAP 5.5" [6.EA] |
| 26 | 238-5608 | DECAL- MK MAX QKREL EM44/54 [2.EA] | 56 | 995-0950 | VELCRO® 2 X 2.9 HOOK |
| 27 | 238-2900 | GROMMET- SPLIT | 57 | 995-0953 | VELCRO® 2 X 2.9 LOOP |
| 28 | 238-2500 | BOLT- MOTOR FITTING | 58 | 209-0620 | CONNECTOR CABLE 24V EM54 ONLY |
| 29 | 995-0339 | CAP- MOTOR FITTING FIN | 59 | 238-3501 | BOLT- 5/16-18 X 1-1/2 SS [4.EA] |
| 30 | 995-3310 | TIE WRAP 8.5" | 60 | 238-3106 | NUT- 5/16-18 SS [4.EA] |
| 31 | 238-1905 | BRACKET/CUP ASSEMBLY | 61 | 237-1714 | LOCKWASHER- SPLIT [4.EA] |
| ■ | 299-0200 | CONTROL MODULE. ASSEMBLY- 12V | 62 | 237-3427 | SCREW- BOAT #12 X 5/8 [4.EA] |
| | 299-0201 | CNTRL MODULE ASSEMBLY- 24V | | | |

EM44

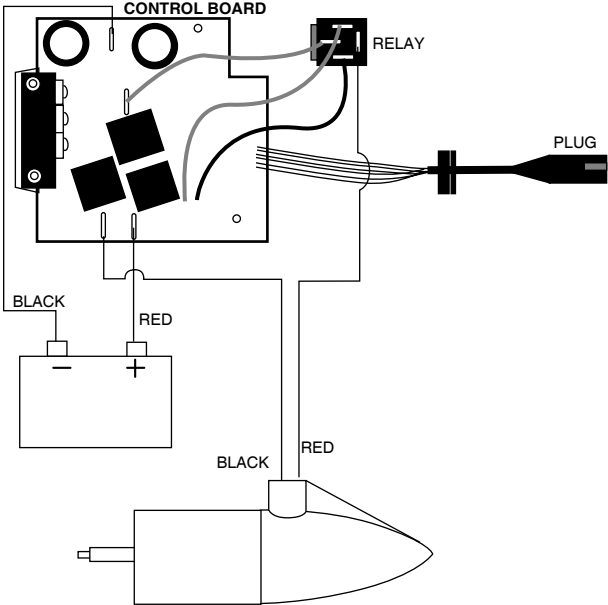

EM54

