

65PD (& SONAR)
65 LBS THRUST
24 VOLT 38 AMPS
54" OR 60" SHAFT

for use with motors with serial numbers beginning MKAE
plain PD models have a 2-year warranty from date of purchase
*PD/US models have a 3-year warranty from date of purchase
*prior year PD/US models had a 2-year warranty

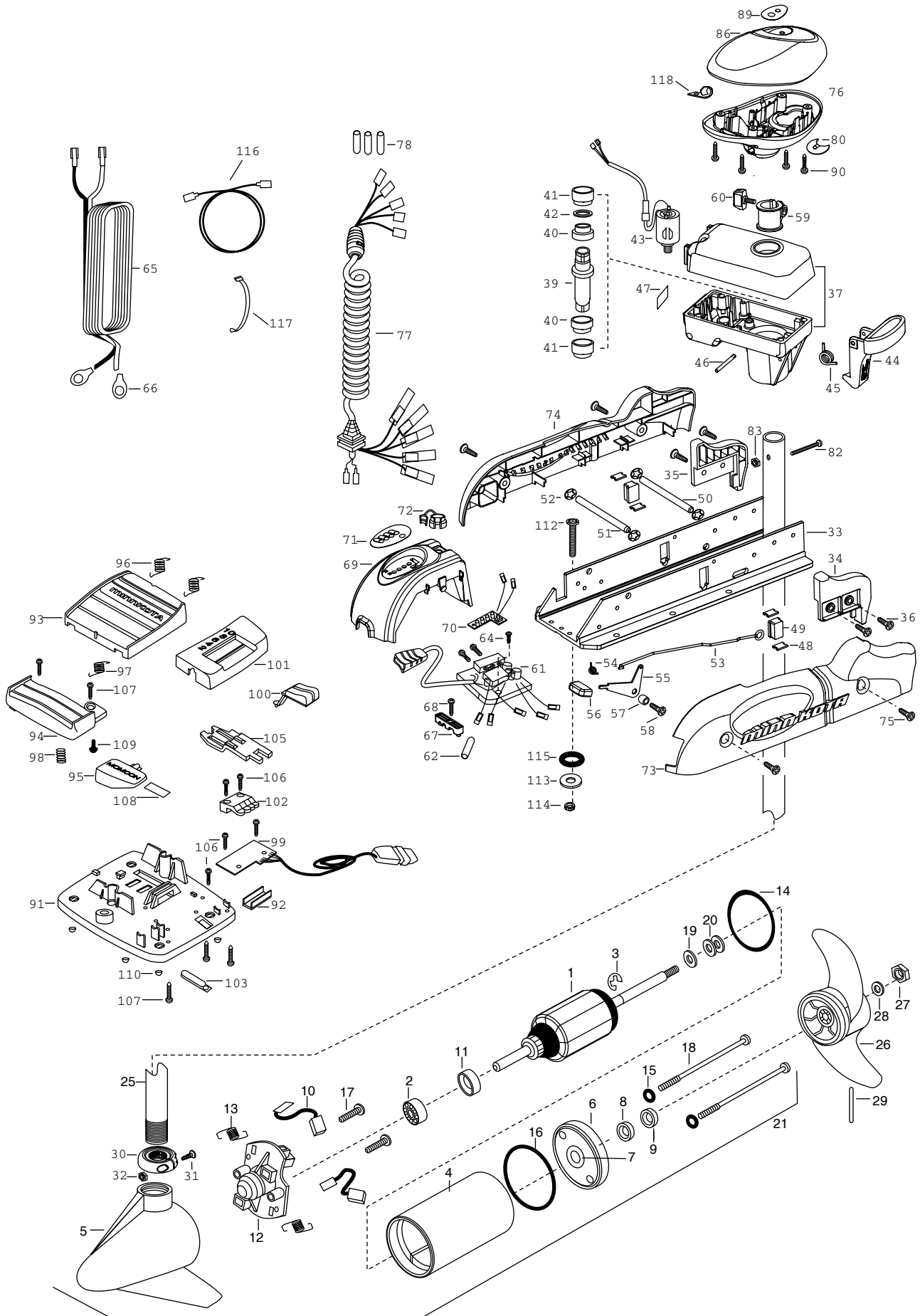

1	92-100-009	ARMATURE ASSEMBLY	■	2882011	BUSHING/ OUTSHAFT KIT	76	2302515	CONTROL BOX PD/AP
2	140-010	BALL BEARING			(INCLUDES 39-42)	77	2991251	COIL CORD WSTRAIN RELIEF 54"
3	788-015	RETAINING RING	*39	2302010	DRIVE HOUSING OUTPUT SHAFT		2991252	COIL CORD WSTRAIN RELIEF 60"
4	431-005	CENTER HOUSING ASSEMBLY	*40	2307304	BUSHING- INNER [2.EA]	78	2065400	WIRE INSULATOR-LGE 1-3/4 [3.EA]
5	421-065	HOUSING BRUSH END 3.62 TXT	*41	2307305	BUSHING- OUTER [2.EA]	80	2224700	INSERT- PLUG
	9421-166	HOUSING BRUSH END 3.62 SONAR	*42	2304603	O-RING	82	2033400	SCREW-10-24 X 1-3/4
6	2-400-101	PLAIN END HOUSING ASSEMBLY	43	2307045	MOTOR- DRIVE HOUSING HIGH SPD	83	2013110	NUT-HEX 10-24 NYLOC
7	144-049	BEARING - FLANGE (SERVICE ONLY)	44	2307205	LATCH HANDLE PD/AP	86	2300235	CONTROL BOX COVER- POWERDRIVE
8	880-003	**SEAL	45	2302750	SPRING- LATCH TORSION PD/AP	89	2315660	DECAL- COVER 65PD
9	880-006	**SEAL WITH SHIELD	46	2302607	PIN- DRIV-LOK GROOVE ZINC TYPE	90	2012100	SCREW-8-18 X 5/8 [4.EA]
10	188-036	BRUSH ASSEMBLY [2.EA]	47	2305514	DECAL-STOW/DEPLOY	■	2774700	FOOT PEDAL ASSEMBLY
11	725-050	BRUSH RETENTION- PAPER TUBE	48	2305110	PAD-PIVOT SUPT [4.EA]	91	2304511	FOOT PEDAL BASE
12	738-036	BRUSH PLATE W/HOLDER	49	2305101	PIVOT PAD [2.EA]	92	2308500	WEAR PLATE FOOT PDL
13	975-040	SPRING - TORSION [2.EA]	50	2300500	PIN-LATCH	93	2304516	FOOT PEDAL-UPPER
14	337-036	**GASKET	51	2300510	PIN-PIVOT	94	2304520	FOOT PEDAL-LOWER
15	701-008	**O-RING, THRU-BOLT [2.EA]	52	2013100	NUT-SPEED [4.EA]	95	2307210	LEVER MOM/CON-
16	701-081	**O-RING	53	2303612	ROD-RELEASE RT/AP SS	96	2302730	SPRING-LONG-UPPER PEDAL [2.EA]
17	830-007	SCREW-8-32 [2.EA]	54	2302700	SPRING-RELEASE LEVER	97	2302731	SPRING-SHORT-UPPER PEDAL
18	830-008	THRU-BOLT 10-32X9.2 [2.EA]	55	2303710	LEVER-RELEASE	98	2302732	SPRING-LOWER PEDAL
19	990-067	WASHER- STEEL THRUST	56	2300101	RELEASE-KNOB	99	2304012	CONTROL BOARD ASSEMBLY-FT PDL
20	990-070	WASHER - NYLATRON[2.EA]	57	2301700	SPACER-RELEASE LEVER	100	2300120	KNOB-SPEED SELECTOR
21	2098032	MOTOR ASSEMBLY 24V 3.62 VARS TXT	58	2303430	SCREW-1/4-20 X 5/8	101	2300121	HOUSING SPEED SELECTOR
	2108032	MOTOR ASSEMBLY-SONAR 24V 3.62	59	2031522	COLLAR- DRIVE (W/INSERT)	102	2302840	ACTUATOR-BOARD
25	2032076	TUBE-CARBON COMPOSITE 54"	60	2011365	SCREW-COLLAR/NEW KNOB	103	2302841	ACTUATOR-MOM/CON
	2032087	TUBE-CARBON COMPOSITE 62"	61	2304044	CTRL BOARD ASSEMBLY-24V PD/AP	105	2302842	ACTUATOR-STEERING
■	1378122	PROPELLER KIT (includes 26-29)	62	2355410	SHRINK TUBE-3/8 ODX2	106	2302100	SCREW-6-20 X 1/2 [5.EA]
26	2091150	PROPELLER W/WEDGE	64	2332100	SCREW-8-32 X 3/8 [3.EA]	107	2372100	SCREW-8-18 X 5/8 [5.EA]
27	2151726	WASHER-5/16 SS	65	2090601	LEADWIRE IOGA 44"	108	2266610	DECAL-ON/OFF SWITCH
28	2053101	NUT-PROP NYLOC 5/16 SS	66	2020700	TERMINAL RING [2.EA]	109	2335130	BUMPER ACTUATOR
29	2092600	PIN-DRIVE	67	2222906	STRAIN RELIEF- BRACKET PD/AP	110	2994807	BAG ASSEMBLY- 4 RUBBER BUMPERS
30	2301545	COLLAR- LATCH PD/AP	68	2303430	SCREW-1/4-20 X 5/8	■	2994803	BAG ASSEMBLY- (BOLT,NUT,WASHERS)
31	2303434	SCREW- 8-32X5/8 MACH PHCR	69	2306555	HOUSING- CENTER PD/AP	*112	2153501	BOLT-MOUNTING-3500 W/STG [4.EA]
32	2303112	NUT 8-32 NYLOC SS	70	2034026	BATTERY GAUGE - 24 VOLT	*113	2151726	WASHER-5/16 [4.EA]
33	2301932	EXTRUSION- BASE MACHINED	71	2306609	DECAL, BATTERY GAUGE	*114	2153100	NUT-5/16-18 MOUNTING [4.EA]
34	2303932	MOTOR REST- RIGHT LARGE 3-5/8	72	2302935	STRAIN RELIEF-DR. HOUSING	*115	2301720	WASHER-MOUNTING RUBBER [6.EA]
35	2303937	MOTOR REST- LEFT LARGE 3-5/8	73	2303941	SIDEPLATE (RIGHT) PD MK	116	2211405	EXTENSION CABLE - SONAR
36	2303430	SCREW 1/4-20X5/8 SELF TAP [4.EA]	74	2303946	SIDEPLATE(LEFT) PD MK	117	2256300	TIE WRAP 5" - SONAR
37	2301845	DRIVE HOUSING PD/AP 2001	75	2303430	SCREW-1/4-20 X 5/8- [4.EA]	118	2052510	CABLE CLAMP - SONAR

****Seal & Oring Kit P/N 2888460** * This item is part of an assembly.This item cannot be sold separately due to machining and /or assembly that is required.

P/N

2314922

REV.D 5-02

65PD Wiring Diagram

